

# Structure

## INTRODUCTION

THE STRUCTURE OF A HOME IS THE SKELETON, WHICH INCLUDES THE FOUNDATIONS AND FOOTINGS AS WELL AS THE FLOORS, WALLS, AND ROOF. STRUCTURES ARE JUDGED BY HOW WELL THEY ARE ABLE TO STAND STILL. SUCCESSFUL STRUCTURES DO NOT MOVE; UNSUCCESSFUL ONES DO, SOMETIMES DRAMATICALLY.

IN THIS SECTION WE WILL DESCRIBE THE PURPOSE OF THE STRUCTURE, AND THEN LOOK AT ALL THE STRUCTURAL ELEMENTS. WHERE THERE ARE SEVERAL TYPES, WE WILL BRIEFLY OUTLINE EACH. WE WILL DESCRIBE WHAT THE COMPONENTS DO, WHAT CAN GO WRONG, AND WHAT THAT MEANS TO THE HOME.

### 1.0 Why Buildings Move

**GRAVITY** What causes structures to move? – In a word, gravity. Gravity is constantly working to get things closer to the ground. Strong structures resist gravity.

**STRUCTURE** There are two common ways a structure may give in to gravity.

**FAILURES** a) If it is sitting on something that is not strong enough, the ground below it will fail. Better to build on bedrock than quicksand.

b) If the structure itself is weak, it will not support the loads imposed on it. The total load is made up of the following –

**Dead load** – the weight of the structure itself, **Live load** – furniture, people, wind, snow and earthquakes.

**WIND** Wind acts intermittently on structures. Wind forces can push, pull or lift buildings. Buildings must be strong enough to resist the lateral and uplift forces of wind as well as the downward force of gravity. Hurricanes and tornadoes are extreme wind conditions. These often result in mechanical damage caused by projectiles.

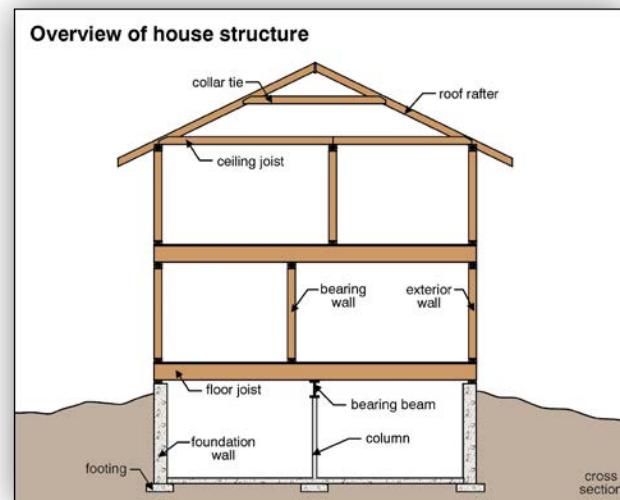

**EARTHQUAKES AND EROSION** Earthquakes also create forces, which can cause structural failures. Like wind, these forces are intermittent and variable and can push, pull or lift buildings. Erosion is a slower form of earth movement, but it can have a devastating effect on structures as well.

**COMPONENT FAILURES** House components may fail because they were poorly built with improper materials, or the materials were poorly assembled. Rot, insects, fire and mechanical damage can cause well-built structures to fail. Rust can attack metal components.

**COMPRESSION AND TENSION** What forces affect individual structural components? The two basic forces are compression and tension. A material is under compression when it is being pushed from both ends. A material is under tension if it is pulled on. Components in compression tend to get shorter or are squashed. Components under tension tend to get longer or are pulled apart. Many building components feel a combination of compression and tension.

Some building materials are good in compression, others work well in tension and some perform well in both. A pile of bricks is very good in compression; you can stand on it. However, it is very poor in tension. A child can pull the pile apart. A chain, on the other hand, is very good in tension. You can pull quite hard on both ends and nothing will give, but the moment you try to push on it, the chain collapses. It is not very good in compression.

**SHEARING AND BENDING** Different materials fail in different ways. Shearing and bending are common modes of failure. Shear occurs when adjacent faces of a material move in opposite directions. When a beam splits, or a brick cracks, it is because of shear.

Bending is movement without shearing. A plank spanned between two chairs will bend if someone stands on it, particularly if they stand near the middle. The upper half of the plank is pushed together under compression; the bottom half gets slightly longer because it is in tension.

Building components that fail by bending are said to sag or buckle. Some materials can bend a significant amount without losing their strength. Brittle materials, however, do not bend much before they break. Ductile materials do. Ceramic tile is brittle, rope is ductile. Some ductile materials are elastic. This means they will go back to their original shape after being bent. A rubber ball is elastic; a nail is not.

**DEFLECTION** Deflection is a mild form of bending. If structures deflect just a little, people do not mind. Building codes stipulate how much deflection is acceptable. A typical floor joist, for example, is allowed to deflect 1/360th of its span.

**MATERIAL SELECTION** What makes a good building material? It should be good at resisting the forces of tension and compression. It should be cheap, easy to work with, light, long lasting, water, rot and fire resistant, and stable under different temperature and humidity levels. No one material does it all. That is why houses are made of many materials. Wood is one of the better materials for small buildings. It is relatively good in both tension and compression. Steel is also good in both tension and compression.

Building materials are chosen based on cost-effectiveness. The goal is to assemble a structure that will perform well for as small a cost as possible. This can lead to some very small margins of safety and, of course, some failures. As new materials are developed, they are tried; in some cases, with great success; in other cases, with very poor results.

The structure is by far the most important part of the house. The safety and usability of the entire home depends on its structural integrity. Since many structural components are buried below grade or behind finishes, much of the structural inspection is done by looking for evidence of movement. Where no movement has occurred, imperfections may go undetected. New interior or exterior finishes and patching work may conceal imperfections over the short term. In these cases, problems will not be identified.

**REPAIRS** Structural repairs can be very costly, and in some cases the problem is so severe that the building is torn down. In many cases, a structural engineer should be consulted before making repairs. An incomplete understanding of a problem may lead to incorrect solutions and a life-threatening situation.

**CHAPTER ORGANIZATION** In this chapter we'll look at foundation configurations briefly, then discuss the various structure components one at a time, starting with the footings and finishing with the roof.

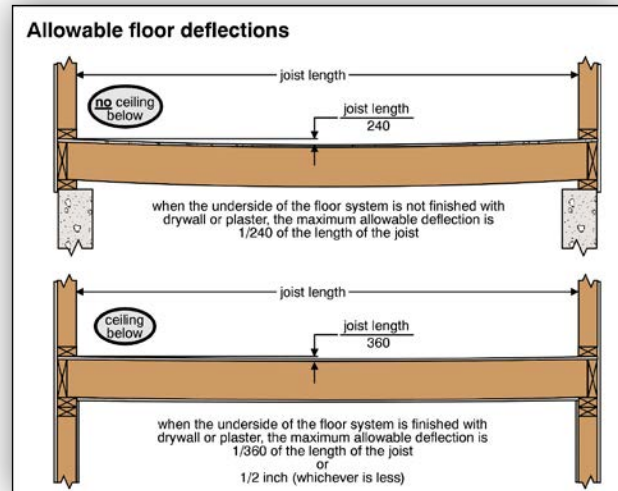

## 2.0 Configuration

Homes may have a basement, a crawlspace, both, or neither. Many houses have partial basements and/or partial crawlspaces. The configuration is determined by climate, cost, regional building practices and restrictions imposed by the building site. In areas prone to hurricanes and flooding, buildings may be built on posts or stilts to keep the home well above grade.

### 2.1 Basement

**DESCRIPTION** Where frost footings are required, a trench is needed around the house perimeter for the footing and foundation system. Since this excavation is necessary, it is not much more expensive to dig a big hole and create a basement. In warm climates where frost footings are not required, basements are rare.

The below-grade space is inexpensive to build once the hole is dug, and can be used for anything from rough storage to living space. Basements commonly contain the mechanical and electrical systems and may include a work room and laundry (although the laundry is upstairs in many modern homes). Game rooms and family rooms are often located in basements, and complete apartments can also be built below grade.

Disadvantages of basements include the susceptibility to water leakage and lack of natural light. Windows in basements are usually small and high on the wall, since most of the wall is underground. Basement ceilings are often low, and even if there is no water leakage, they can be cool and damp.

### 2.2 Crawlspace

**DESCRIPTION** Where a trench is dug for the foundations, and the earth under the house floor is not removed, a crawlspace is created. It may have an earth floor, although a concrete slab is more desirable for storage and moisture control. Many modern codes call for crawlspaces to be 36 inches high where access must be gained, although many old crawlspaces are less. Some are entirely inaccessible. Restricted access makes inspection, maintenance and repair more difficult and expensive.

**VENTING** Crawlspaces are often ignored for long periods. Where moisture levels are high, structural damage, due to rot and insect activity, can go unnoticed. Some building standards call for one square foot of venting for every 500 square feet of crawlspace area. This is rarely provided. Where the crawlspace is dry, this may not be a problem.

## 2.3 Slab-on-Grade

**DESCRIPTION** In this type of construction, a poured concrete floor rests directly on the ground. The concrete slab is at least three inches thick and may or may not be reinforced with steel bars. Immediately below the slab, a moisture barrier is typically laid over about six inches of gravel. In modern construction, insulation is often provided below the slab. Slabs are typically supported by footings and foundations.

There are several types of slab-on-grade construction, including monolithic slab, supported slab, and floating slab. A monolithic slab is a concrete floor and foundation all poured as one. This can be thought of as a floor slab that is thicker around the edges.

A supported slab is not poured together with the foundation, but it does rest on the foundation. The footings and foundation wall are installed first, with a ledge at the top of the foundation to support the slab. Basement floor slabs are often supported slabs.

The floating slab is entirely independent of the foundation. The foundation is poured or built first. The slab is not supported by or connected to the foundation. This type of slab is common in garages.

From an inspection and maintenance standpoint, slab-on-grade is more restrictive than homes with basements or crawlspaces because none of the foundation is accessible.

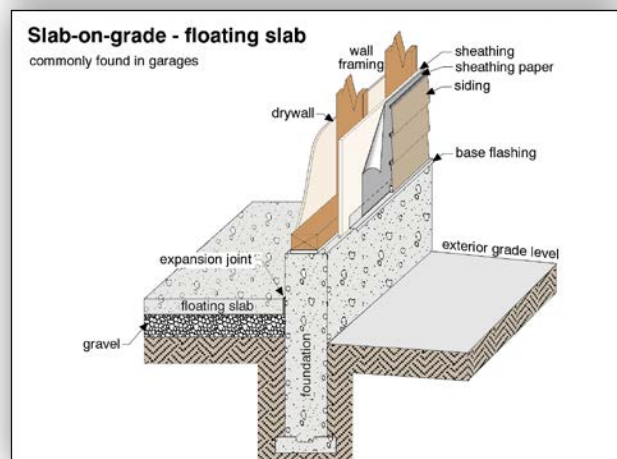
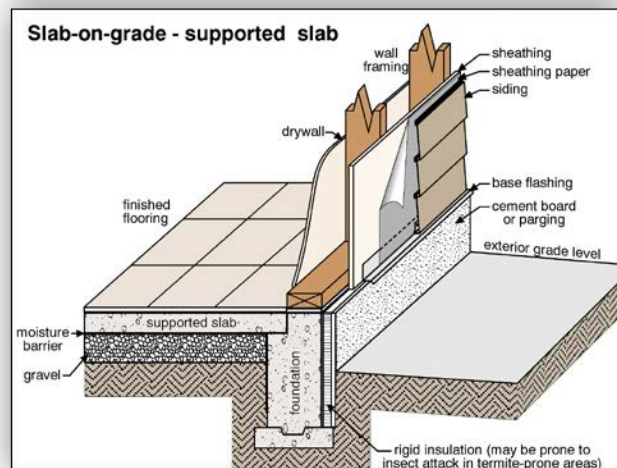
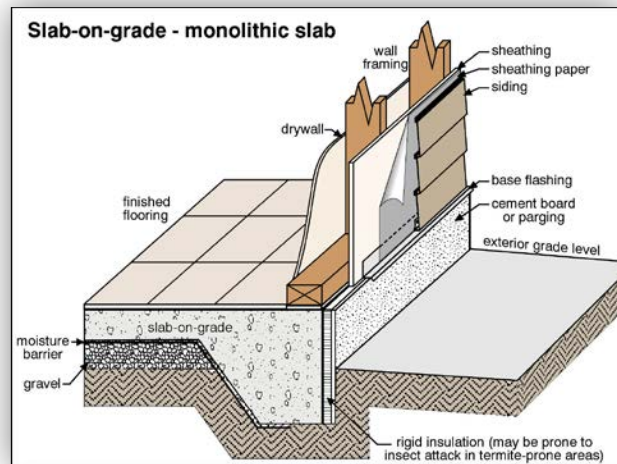

**SYSTEMS CONCEALED** Basement or crawlspace floors are often left as exposed concrete. Problems with water or insect infestation, for example, can be picked up early. With slab-on-grade, the concrete slab is normally covered by subflooring and finish flooring. Problems can go undetected for some time.

Where the slab is poor quality concrete, too thin, or missing the reinforcing bar, the floor is prone to cracking and shifting. Subsurface erosion can also result in slab failure, as can areas excavated for plumbing or heating pipes. This leads to broken, uneven floor surfaces with more points of entry for water and insects. Substantial shifting can damage the plumbing, heating and electric services buried in or below the slab. Expansive soils can heave the slab, resulting in similar problems.

### 3.0 Footings

**DESCRIPTION** The function of footings is to transmit the weight of the house to the soil, without allowing the house to sink. Footings are located below the foundation walls, or at the perimeter of slabs, and below columns or piers. The horizontal surface of the footing is larger than the foundation, so the load of the house can be spread out over a wide area. Footings are typically 16 to 24 inches wide and six inches to 16 inches thick. In cold climates, footings carry the house loads below the frost line. The heavier the building and the weaker the soil, the larger the footing should be.

Footings may be concrete, brick or stone. In modern construction, most footings are poured concrete, often reinforced with steel bars.

**FOOTING TYPES** Strip footings (also called spread footings) run continuously below foundation walls, typically around the building perimeter. Pad footings (also called spot footings) are smaller and typically support columns or piers.

**PIER AND GRADE BEAM** Pier and grade beam construction is common in areas with expansive soils. Concrete piers are poured down to a depth where the soils are stable. Grade beams, which often form foundation walls, span between the piers. These grade beams are often reinforced concrete.

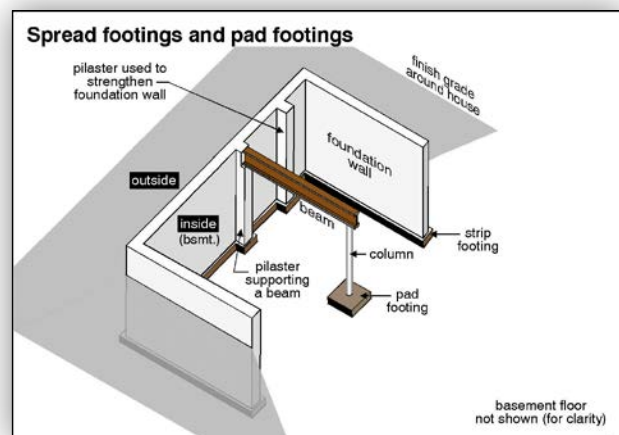



## Common Problems with Footings

When the footings fail, the entire house moves. This is often a very serious problem. It is almost always expensive, and sometimes impossible, to correct. Since the footings are located below the soil, they cannot be seen. It is often difficult to know why they have failed.

Settlement is the most common form of failure, although heaving is common in cold climates due to frost expanding the soil below footings.

Sometimes footings fail in one area, and in most cases the failure is not uniform, (i.e. the building does not sink straight down but leans to one side or another). Often, one part of the house will pull away from the rest. This leads to cracking of interior and exterior wall surfaces.

**SETTLEMENT – WEAK SOILS**

Soils prone to compaction or movement do not support footings well. This includes recently disturbed soil. For example, if an excavation for a foundation is dug too deep, then backfilled to the correct depth, the disturbed soil under the footing is likely to compact over the first few years, resulting in building settlement.

**SETTLEMENT – ABSENCE OF FOOTINGS**

This is not common on professionally-built houses, but may occur in casual construction as well as on porches and poorly built additions. Some homes were built on mud sills – wood beams laid on the ground with walls built on top of the beams. These mud sills are replaced with a foundation and footing system as the sills rot, heave or settle.

**SETTLEMENT – UNDERGROUND STREAMS**

These may erode or weaken soil below the footings, causing severe building settlement. It is, of course, very difficult to locate and trace underground streams. They often flow only at certain times of the year.

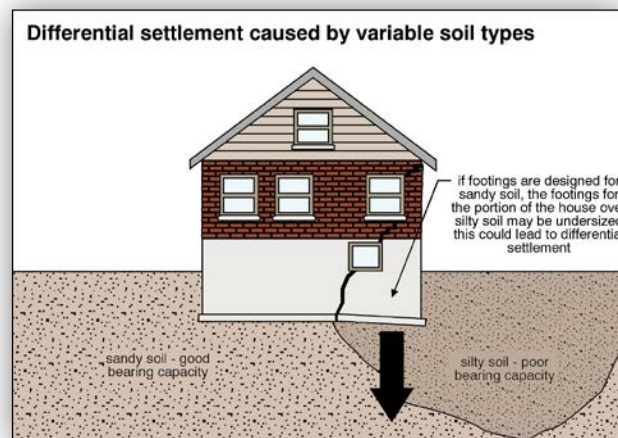
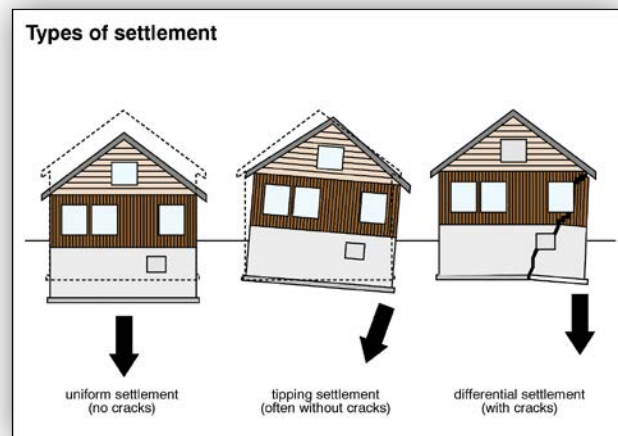



**SETTLEMENT – UNDERSIZED FOOTINGS** Settlement may be the result of poor design, or an additional load that has been added. For example, when a second floor is added to a bungalow, the weight may cause the footings to sink. The additional weight of a masonry chimney can also cause localized footing failure.

**SETTLEMENT – FOOTING DETERIORATION** The footing must be strong enough not to break apart under a load, and must be able to stand up to continuous exposure to damp soil.

**SETTLEMENT – UNDERMINED OR CUT FOOTINGS** If the basement floor is lowered, there is the risk that the footings will be broken off on the inside or will lose their support. Even if excavation is not done below the footings but down to the bottom of them, the lateral support for the footing may be lost, and the footing and foundation wall may move inward.

**SETTLEMENT/WALL FAILURE – LOWERED BASEMENT FLOORS** When a basement floor is lowered, the footings should be underpinned (lowered and, in some cases, enlarged). Alternatively, only the central section of the basement should be lowered, to avoid disturbing any of the soil near the footings. Depending upon how much the basement floor is lowered, the required clearance from the footings varies. A soils engineer is often consulted and a concrete curb (also called a bench footing or Dutch wall) may be needed around the inside edge of the footings to ensure they are not compromised. Building settlement and failure of foundation walls are both risks when lowering basement floors.

One of the dangers in lowering basement floors is the increased risk of basement leakage. Notice in the following illustrations how the drainage tile outside is no longer in the correct location once the floor is lowered. It is too high to be effective.

When excavation is done on the exterior, (e.g. for an addition or swimming pool) the footings can be damaged or undermined in a similar fashion.

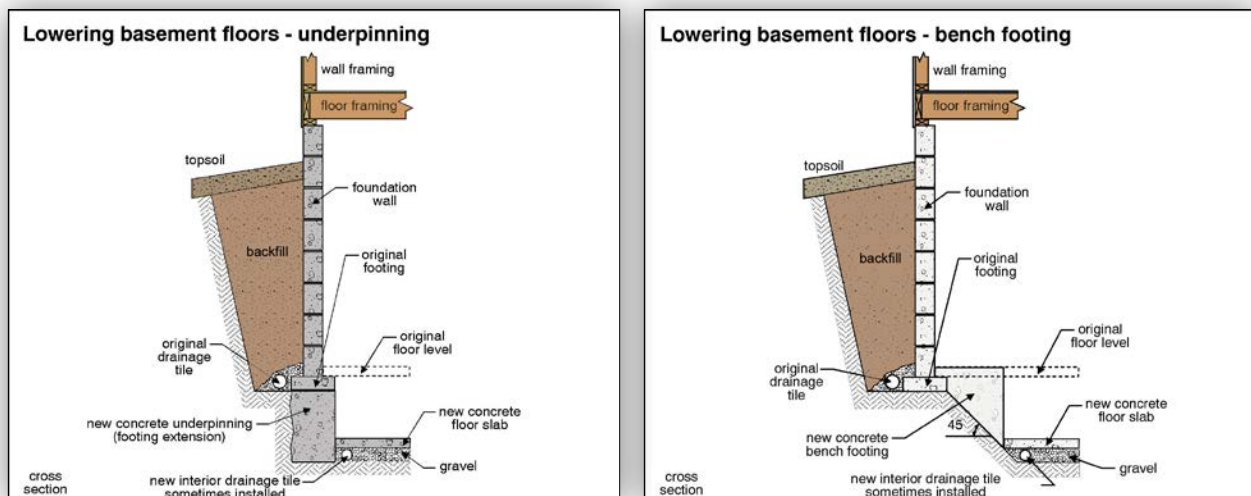

**SETTLEMENT – LOT SLOPE** – Houses built on or close to slopes may be subject to failures as a result of soil moving down the slope. This may be a slow steady process or a sudden event triggered by heavy rains for example. This can be extremely costly to correct.

**SETTLEMENT – CUT AND FILL LOTS** – Houses built on sloping lots may be more prone to footing and foundation failures. The chances of building on disturbed soil are increased on lots such as these. Efforts made to level and terrace the lot may result in soil being cut out of the hill to form a level terrace under the back half of the house. This soil is then used as fill in the adjacent area where the front half of the house is to stand. The downhill half of the house may be built on fill that may not be well compacted or may not be able to stay in place and support the house.

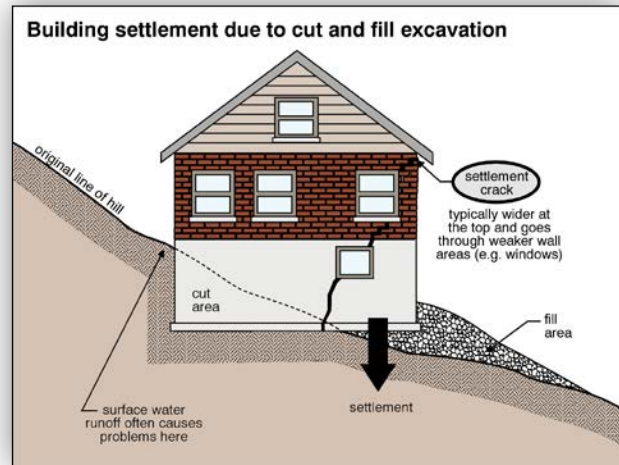

On sloping lots, large lateral earth thrust and hydrostatic pressure can be built up by the soil on the high side of the home.

Water running down the slope is blocked by the building and accumulates here.

On the downhill side, the footings may not be deep enough in cold climates. Frost heave can result where the footings are less than four feet below grade. The side of the house with the lower grade often has a walk-out basement, and chances of a footing being too shallow are greatest here.

**SETTLEMENT/ HEAVING – EXPANSIVE SOILS** – Some clay soils that expand and contract significantly with different moisture contents may also result in failure. These expansive soils can heave floors and foundations when they get wet. When they dry, they shrink and allow the building to drop. This is a significant cause of house structure problems in some areas.

Tree roots can affect the moisture content of soils noticeably. Most soils have strengths that change with different moisture contents. Some clay soil strengths change dramatically. These are poor building soils. Silts are also poor building soils, in many cases much weaker than clay.

**EXPANSIVE SOILS AND SLAB-ON-GRADE HOMES** Where expansive soils are common, heaving soil below the slab can push the slab upwards at the center or at the perimeter, breaking the concrete and damaging utility lines. Where these soils are common, the slabs are sometimes post-tensioned. This means there are steel reinforcing cables laid within the slab and project beyond the slab edge. The cables are tightened after the concrete is poured to strengthen the slab, helping it resist the forces of the expansive soils. The slabs are sometimes thickened in places, often with beams running in both directions on the underside of the slab. These are called ribbed foundations.

The expansive soils below the slab are often saturated during construction before pouring the slab so the soils will be a maximum height when the slab is poured.

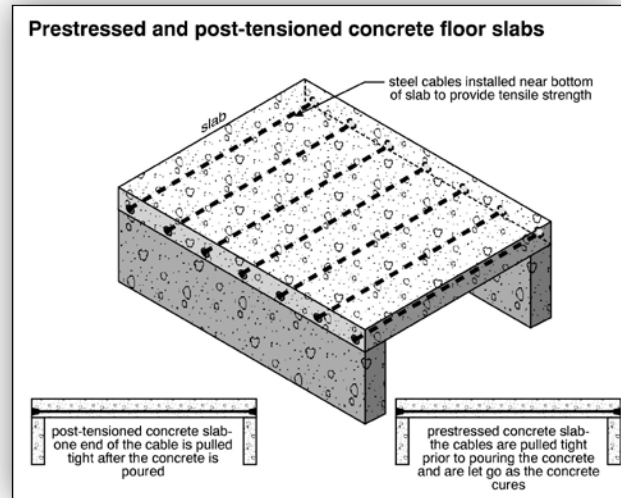

- FROST HEAVE – FOOTINGS TOO SHALLOW** If the footings and foundations are not deep enough, the ground below them may freeze. Frozen ground expands and may pick up all or part of the building. This can do serious damage.
- FROST HEAVE – OUTSIDE BASEMENT STAIRWELL** Exterior basement stairwells may compromise the footings in cold climates. In order to be effective, the footings in cold climates must be below the frost level. When an exterior basement stairwell is added, the stairwell opening effectively lowers the exterior grade level, and also lowers the depth to which frost can penetrate. After the stairwell is in place, the frost can go several feet below the bottom of the stairwell opening. This can lead to frost heaving of the footings and the foundations.

A properly added exterior stairwell will include deepened foundations, or a completely insulated approach, to prevent frost penetration below the building footings.

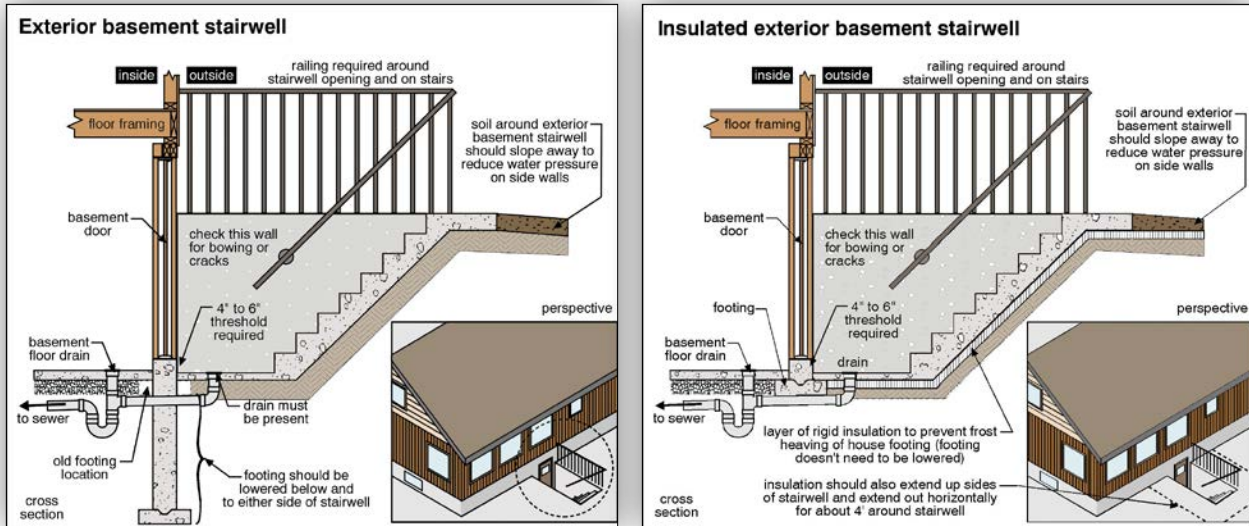

**IDENTIFYING THE PROBLEM** During an inspection, the results of footing failure can usually be seen. It is, however, difficult to know whether the building is still moving, and if so, at what rate. It is often necessary to monitor the building over a period of months or even years, to know whether the problem will warrant repair. Many footing failures are not severe enough to warrant repairs.

**REPAIRS – UNDERPINNING** The usual corrective action is to underpin the footings. This means digging under the existing footing, and adding a new footing wider and/or deeper than the original. This may have to be done in small sections on strip footings since one cannot excavate under the entire house at one time. Usually two to four foot sections are done at a time. This is very expensive work.

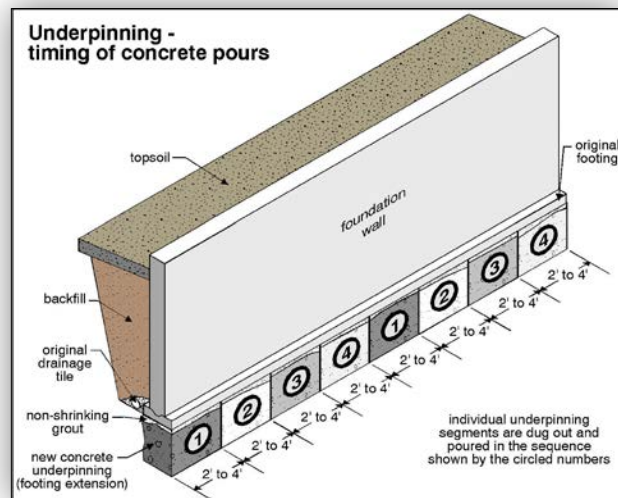

**REPAIRS – PILES AND HELICAL ANCHORS** In some cases, where the soils are moving or are likely to move, underpinning is not appropriate. Piles driven deep into the ground are an alternative, but may not be cost-effective for an existing building. Helical anchors are sometimes screwed into the soil to support failed footings.

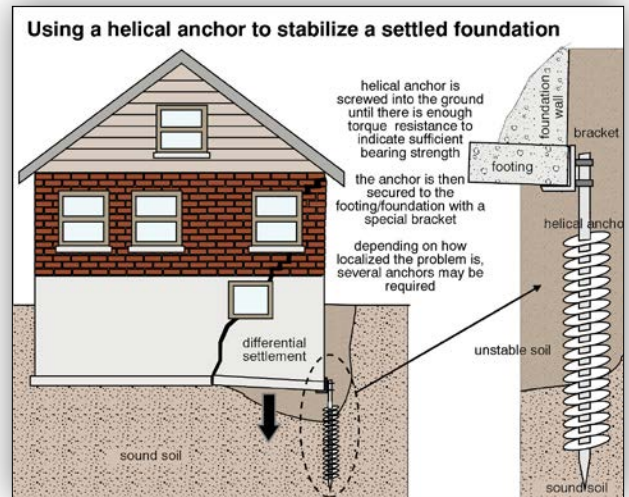

## 4.0 Foundations

### 4.1 General

**DESCRIPTION** Foundations transmit the weight of the house from the above-grade walls and floors down to the footings. Where there is a basement or crawlspace, foundations also resist the lateral pressure of the soil. The foundation acts as a retaining wall in this sense. In cold climates, foundations carry the weight of the house below the frost line to prevent frost heaving.

Typical foundation materials are stone, brick, poured concrete, concrete block, cinder block, insulated concrete forms, clay tile, and wood. Most of these materials behave similarly. Wood foundations are the exception.



**COMMON FOUNDATION TYPES** Foundations may be continuous walls (stem walls), often made of concrete, masonry block or insulated concrete forms (ICF). Foundations may also be piers supported by pad footings.

Where flooding is a risk, homes may be built on piers that are well above grade. Piers may be below grade, and may be connected by grade beams.

Where soil conditions are poor, the building may rest on piles that are driven or turned down into the ground to some depth to provide adequate bearing strength to support the home.

Two common foundation arrangements are illustrated below.

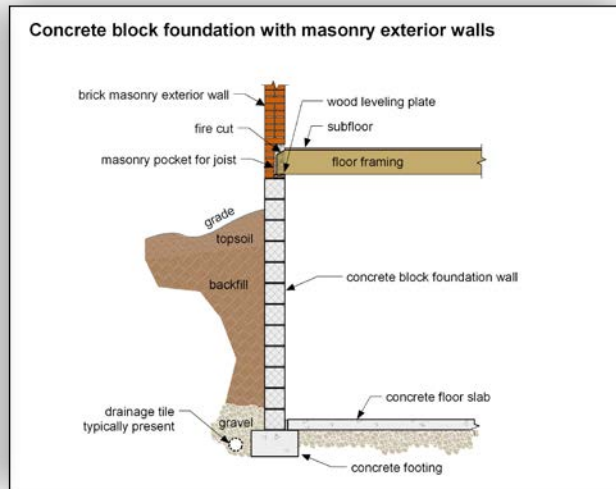
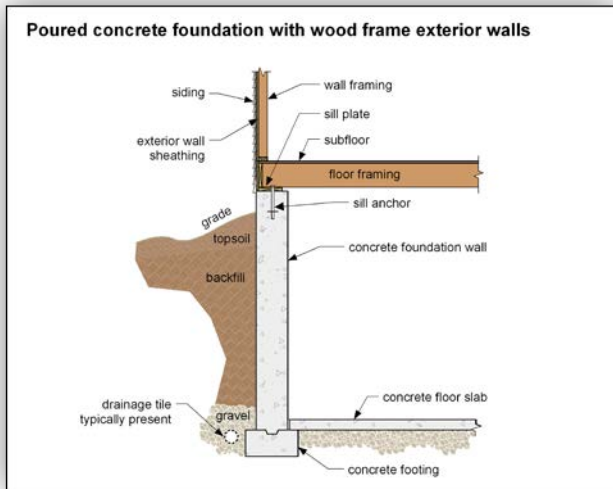

### Common Problems with Foundations

**CRACKS/ BOWING/ SPALLING** Foundation walls may crack, bow, spall or shift. Cracks may be due to shrinkage, settlement or lateral forces. Some cracks are serious while others are insignificant. Bowing is usually the result of lateral forces. Spalling indicates poor quality materials or chronic water problems. Some of the causes of foundation defects are outlined below.

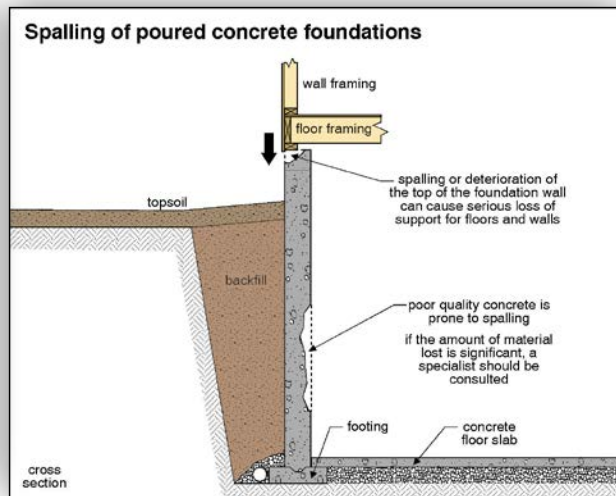
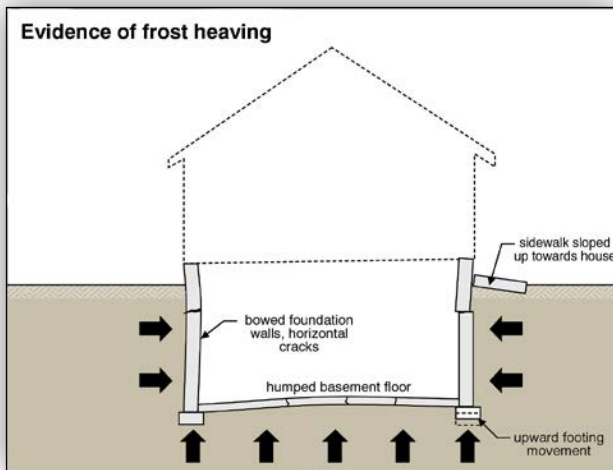

**INADEQUATE LATERAL SUPPORT** Basement and crawlspace foundations are really retaining walls, holding back the soil outside. If the foundations do not provide enough lateral support, they will deflect inwards. This may be the result of mechanical forces exerted during back-filling; back-filling with frozen soil (cold climates only); unusual frost development in the soil immediately outside the building (cold climates only); foundation walls that are too thin, too tall or do not have adequate reinforcement; or the house floor system does not provide adequate bracing for the top of the foundation wall. This last problem is common on the high side wall on a sloping lot. Both masonry walls and poured concrete walls can fail if not properly built.

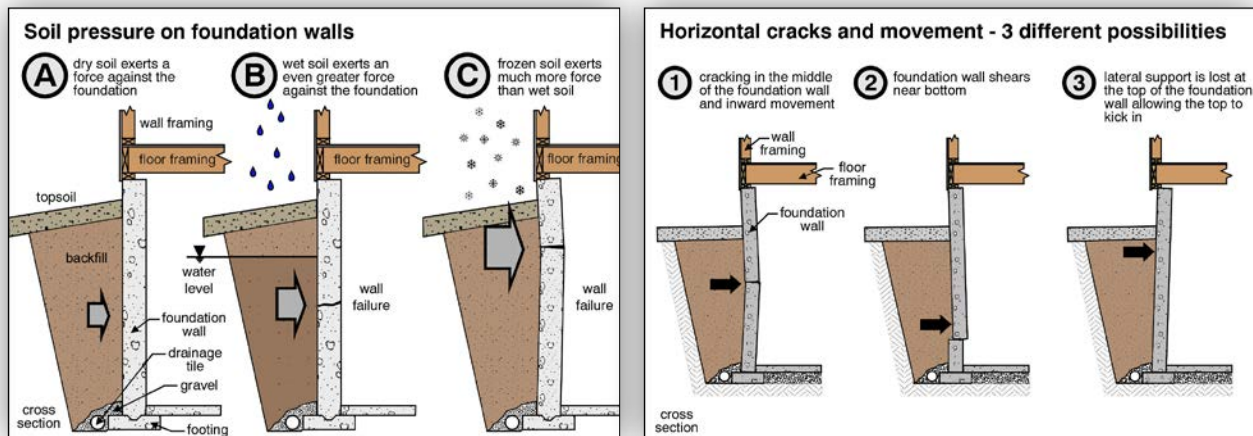

**INWARD BOWING** Foundation walls that move inward can be repaired by tying them back from the outside, using ties and anchors. Alternatively, buttresses can be provided on the interior. These often are concrete or concrete block structures built against the basement walls. Steel beams are sometimes used. There are also modern structural fabrics that can be applied to strengthen walls. Another choice is to build a new foundation wall inside the old. In some cases the foundation is replaced.

**BOWING/ CRACKS – MECHANICAL DAMAGE** Mechanical damage caused when backfilling during construction for example, can generally be repaired on a localized basis, although re-excavation is often necessary. Using heavy equipment next to the home (to re-pave a shared driveway, for instance) can also exert high horizontal loads and result in bowing and cracking in the foundations of one or both houses.



**BOWING/ CRACKS – HEIGHT OF BACKFILL** The height of soil outside a foundation may exert enough force to cause the foundation to fail. Conventional foundations can typically tolerate 3 feet to 7 1/2 feet of soil height on the outside. The strength of the foundation is determined by its material – concrete or concrete block for example, the strength of the concrete, the thickness of the wall, whether the wall is laterally supported at the top, and whether the wall is reinforced.

**Thickness of foundations (laterally supported)**

poured concrete (3000 PSI)		poured concrete (2000 PSI)		concrete block	
thickness	maximum height	thickness	maximum height	thickness	maximum height
6"	6'-0"	6"	5'-0"	6"	2'-6"
8"	7'-6"	8"	7'-0"	8"	4'-0"
10"	7'-6"	10"	7'-6"	10"	6'-0"
12"	7'-6"	12"	7'-6"	12"	7'-0"

**Thickness of foundations (laterally unsupported)**

poured concrete (3000 PSI)		poured concrete (2000 PSI)		concrete block	
thickness	maximum height	thickness	maximum height	thickness	maximum height
6"	2'-6"	6"	2'-0"	6"	2'-0"
8"	4'-0"	8"	3'-0"	8"	3'-0"
10"	4'-6"	10"	4'-0"	10"	4'-0"
12"	5'-0"	12"	4'-6"	12"	4'-6"

**BOWING/ CRACKS – TREE ROOTS** The force exerted by large tree roots on the foundation wall can lead to deflection of the foundations. Some soil types shrink considerably as they dry out. If a large tree draws water from such soils below a footing, the footing may drop as the soil compacts. In this case, the tree damages the house without actually touching it.

In the short term, tree root damage can be arrested by cutting down the tree and leaving the roots in place. Over the long term, the roots may be expected to rot, leading to soil settlement, resultant water leakage and, in some cases, building settlement. The roots may have to be removed.

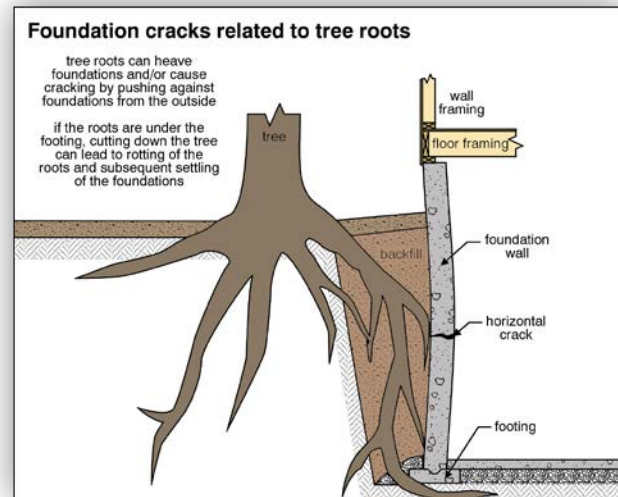

**SPALLING/ DETERIORATION – WATER PENETRATION** Water penetration can deteriorate the mortar in masonry foundations, reducing its strength and ultimately allowing shifting to occur. This is usually a slow, long-term process.

- SPALLING/ DETERIORATION – SURFACE WATER** Water related problems and wall deterioration due to moisture penetration can be minimized or eliminated with control of surface water on the exterior. Good exterior grading with ground sloping down away from the building is important. Proper performance of gutters and downspouts is equally important. All roof run-off must be directed into a drainage system or onto the ground at least six feet away from the building.
- SPALLING/ DETERIORATION – GROUND WATER** Where ground water is the problem (an underground stream or high water table), grading and downspout approaches may not prove adequate. Drainage tiles and/or a sump and pump, are often necessary. Consultants specializing in situations such as these should be engaged. See Section 10 in the Interior chapter.
- SPALLING/ DETERIORATION – POOR QUALITY CONCRETE** Low quality concrete subjected to damp soils may deteriorate, losing its strength. This is common in poured concrete foundations, built in the early 1900s. The interior or exterior face of the concrete may crumble (spall). Reducing moisture penetration will retard this action, but if the damage has progressed to a point where the structural integrity is compromised, sections of the foundations may have to be completely replaced. This is an expensive undertaking.
- SPALLING/ DETERIORATION – POOR QUALITY MASONRY** Some bricks are designed for use below grade, but many are not. The use of inappropriate brick will result in a shortened foundation life. Ultimately, the bricks have to be replaced.
- FOUNDATIONS TOO SHORT** If the foundation walls do not extend well above grade level, the walls sitting on top of them may be exposed to damp soil and rot or deteriorate. Foundations should extend at least four to six inches above grade level.

### Common Problems in Cold Climates

- FROST HEAVE – TOO SHALLOW** In cold climates, if the foundations are too shallow, frost may heave even the best-built footings and foundations. On sloped lots, the possibility of shallow foundations is greatest on the low side. Properties with basement walk-outs are often vulnerable to freezing damage.
- FROST HEAVE – UNHEATED HOUSES** Conventional cold climate construction assumes the house will be heated. An unheated house may have frost penetrating through the basement floor below the footings, leading to heaving. There is a risk involved in leaving a house unheated.

**ADFREEZING** Adfreezing is a phenomenon whereby damp soil on the outside of the building actually freezes to the building and as the soil heaves, it will lift the top part of the foundation wall. Horizontal cracks in foundation walls just below grade are typical.

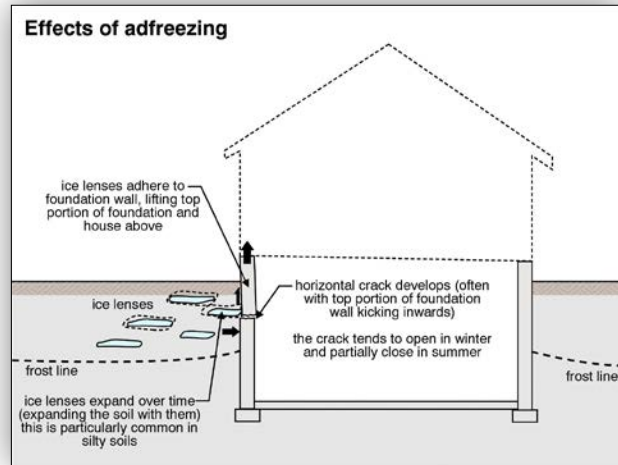

### 4.2 Wood Foundations

**DESCRIPTION** Preserved wood foundations were introduced in the early 1960s. Several thousand units have been installed. Life expectancies of the below-ground wood are estimated in the 50 to 100 year range, considerably less than many traditional building foundation materials. Some manufacturers offer 60 year limited warranties.

The wood is chemically treated to retard rot. Chemical treatment for wood used in foundations is more intensive than that typically used in wood for decks, fencing, etc. The wood foundations may rest on concrete or wood footings. With wood foundations, special care must be taken to ensure that the foundation is able to perform its retaining wall function (adequately resisting lateral forces).

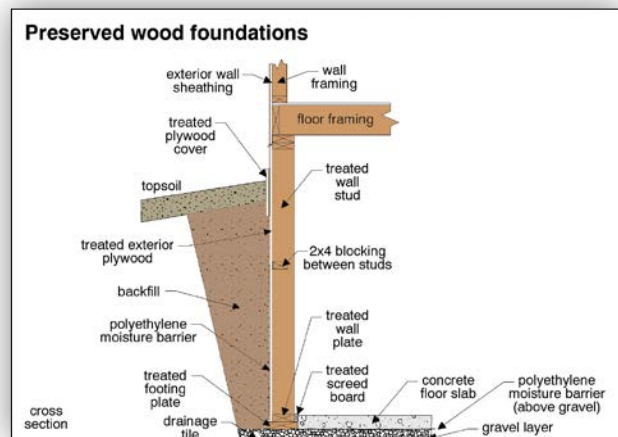

## Common Problems with Wood Foundations

**ROT/INSECT DAMAGE** Rot and insect damage are the major enemies of wood foundations. Wood foundations should not be used in areas prone to wood-destroying insects such as termites.

### 4.3 Pile Foundations

**DESCRIPTION** Piles are steel, wood or concrete columns driven into the soil. They are used in weak soils and may extend down through the poor soil, to reach a soil with good bearing strength. Piles may depend on friction between the sides of the pile and the soil for their support. They may also be point bearing at the bottom. The building itself rests on beams or walls that straddle the piles. Piles are expensive and once the building is up, there is often no way to know if piles have been used and where. Again, the presence or absence of building settlement is the only way to determine how successful the approach has been.

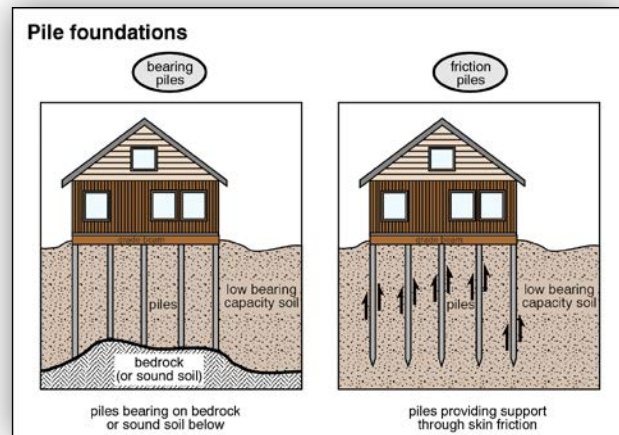

**PILES AND GRADE BEAMS** In some areas, garages are typically constructed on piles. The piles support poured concrete grade beams for example, which in turn, support the floor and wall systems. The garage floor is then poured on the undisturbed soil.

### 4.4 Pier Foundations

**DESCRIPTION** Where continuous foundations are not provided, individual columns or "piers" may be used to support a building. The piers should rest on a footing below the frost line in cold climates and typically the pier supports a beam. The beam, in turn, supports the floor, wall and roof loads. Piers are commonly found in houses where there is no basement or a partial basement. A crawlspace often has a pier system supporting the structure above. Porches are also commonly supported by piers.

Piers may be stone, brick, concrete block, cinder block, or wood. Most of these materials behave in a similar fashion. Wood, of course, is the most vulnerable to rot and insect damage. As a rule, wood/soil contact is best avoided.

Concrete piers are often used with grade beams where expansive soils are an issue.

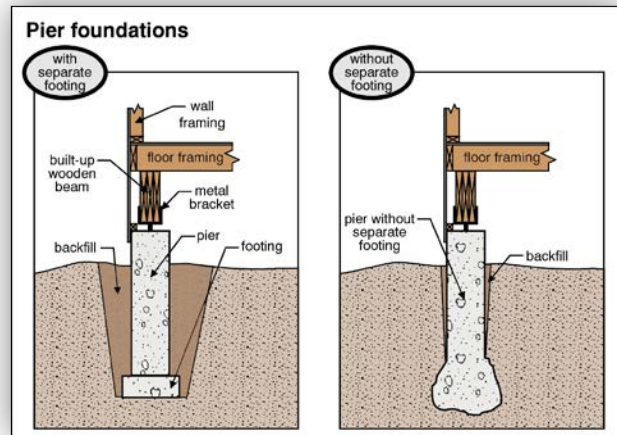

### Common Problems with Piers

**SETTLEMENT – INADEQUATE FOOTINGS** Pier problems are often the result of inadequate footings. This will result in settlement of the pier and, of course, the building above. If the pier base is not below the frost line in northern climates, frost heaving can be a problem. In both these cases, the piers usually have to be rebuilt. Similar problems can result in areas with expansive soils.

**OVERSPANNED** If the piers have too great a span between them, the beams may sag or the concentrated loads may cause the piers to sink. Adding piers is the typical solution here.

**TOO SLENDER OR OUT OF PLUMB** If the piers are too slender or are out of plumb, they may not be capable of carrying their intended loads. Diagonal wood braces are used in some areas to help hold piers in place. Piers that are deteriorated as a result of moisture or mechanical damage should be repaired or replaced as necessary.

Wood piers can rot, be attacked by wood-boring insects, fire or be damaged mechanically.

**SKIRTING** Preserved wood performs better than most species of untreated wood. Where piers are used in lieu of a continuous foundation, the space between the piers usually has to be filled in to prevent soil from falling into the basement or crawlspace. In above-grade situations, skirting keeps out animals and, to some extent, rain, snow and cold. Skirting may be wood, masonry or poured concrete, for example. Where the skirting is not structural, repairs to deteriorated skirting are often deferred. Wood skirting often deteriorates where it contacts the soil.

## 5.0 Floors

Floors provide the bearing surface for people and furniture. They also tie the building together, adding rigidity and providing a surface for floor coverings above and ceiling finishes below. We will look at floor components one at a time.

### 5.1 Sills

**DESCRIPTION** Wood sills provide a level, continuous pad between the foundation top and the bottom of the framing system. The sills secure the floor system to the foundation.

**ANCHORED TO FOUNDATION** Typically, the floor joists rest directly on and are secured to the sill. Sills should be anchored to the foundation. This is often accomplished using bolts anchored into the top of the foundation wall, passing through the sill and secured with a washer and nut.

In new construction, the sill is typically a wood framing member (2x4 or 2x6) laid flat. In older construction it may be a substantial wood beam (e.g. 8x8). Wood sills can support wood framing members but should not support brick or stone.

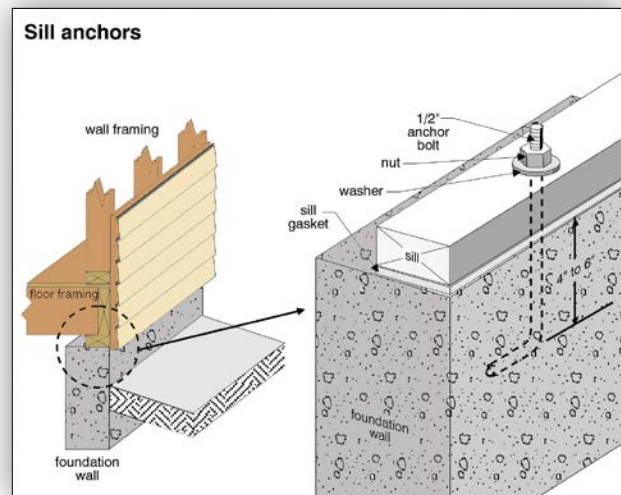

### Common Problems with Sills

**CRUSHED – CONCENTRATED LOADS** Sills may be crushed as a result of concentrated loads. Steel posts built into walls will sometimes cause this.

**CRUSHED – INADEQUATE END BEARING** If the beams or joists are too short, and only the very end rests on the sill (less than one inch, for example), the concentrated loads may crush the sill.

**MOVEMENT – INADEQUATE ANCHORING** Where the sills are not secured to the foundations, there is danger of the building shifting during high winds, when significant upwards and lateral forces can be generated.

**ROT/INSECT DAMAGE** Wood sills close to grade level are subject to rot and insect attack because they are wet much of the time. Soil is typically damp. Sills may rot and crush under the weight of the framing system. This will weaken the structure, allowing it to settle slightly and break the connection between the floor and foundation.

### 5.2 Beams

**DESCRIPTION** Beams carry floor and wall loads horizontally to the foundations, walls, columns or posts. Beams may be wood (solid, built-up or engineered), plywood or steel.

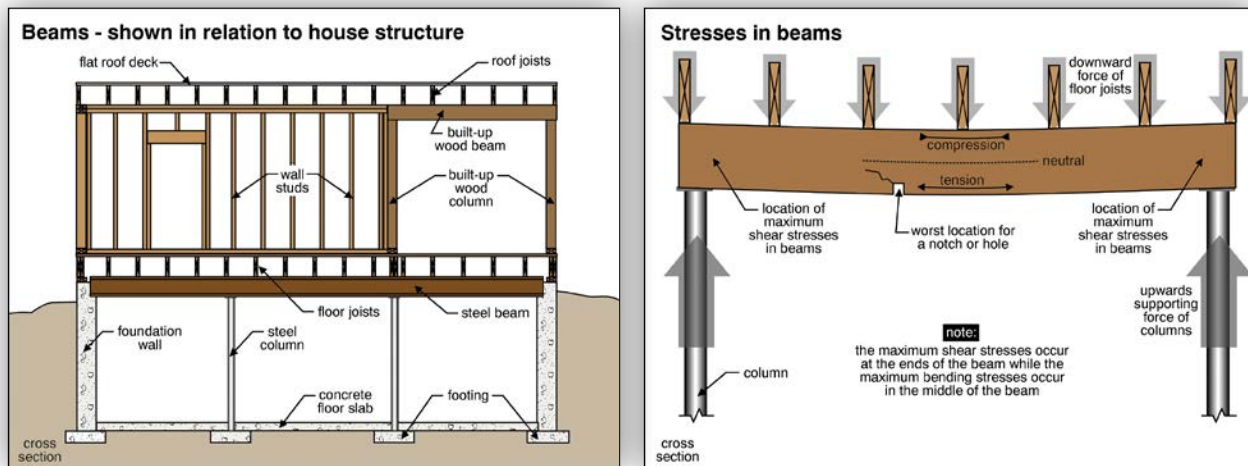

### Common Problems with Beams

**SAG – OVERSPANNED** Undersized or overspanned beams may sag or crack. This may lead to failure of the entire framing system. Fortunately, this rarely happens, and almost never suddenly. Overspanned wood beams can usually be identified readily, and posts can be added or the beam can be strengthened.

**CRUSH/FALL – END BEARING** Where the end bearing is inadequate, the beam can crush itself or its support. There is also potential for the beam to slip off its support. Typically, three inches is considered a minimum end bearing for beams when supported by masonry or concrete.

**ROT/INSECT DAMAGE** Wood building components are vulnerable to rot, damage, insect attack and fire. Rot and insect damage are common where there is wood/soil contact. Beams below grade should have 1/2 inch clearance along the sides and at the end to allow for air circulation.



**DAMAGE/ NOTCHED/ DRILLED** Mechanical damage can be done accidentally or intentionally. Wood beams that are notched, cut or drilled are weakened. The location and size of the damage determines whether corrective action is necessary.

**TWISTING/ ROTATION** Rotation of wood beams due to warping or poor support is relatively uncommon but can lead to damage and ultimate failure.

**NAILING AND BUTT JOINTS** Built-up wood beams may not be adequately nailed. Normally, nails should be provided in double rows every 18 inches along the beam. Where butt joints occur in wood beams, they should be located over the supports or as follows: the butt joints should be within six inches of the quarter point of the span. For example, if the span is 12 feet, the joint should be within six inches of the three-foot mark or the nine-foot mark of the span; (i.e. the joints should be 2-1/2 to 3-1/2 feet from the end supports).

**RUST** Steel beams are susceptible to rust, particularly if the basement is damp. Steel should be painted to prevent rust. Lateral support for steel beams is typically provided by wood strapping secured to the joists.

**LATERAL SUPPORT** Lateral support for steel beams is typically provided by wood strapping secured to the joists. There are several ways to provide lateral support for wood beams. See the illustration below.

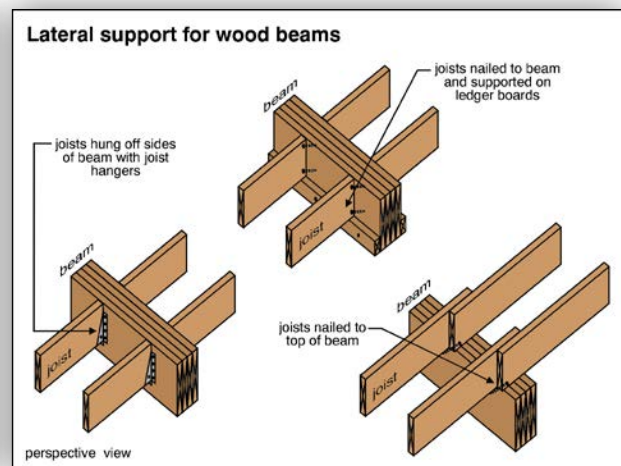
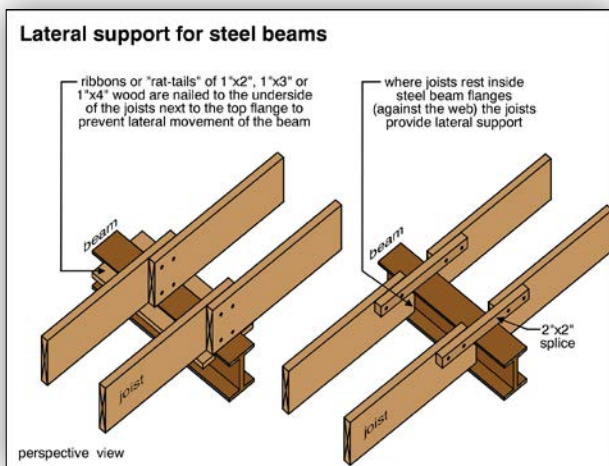
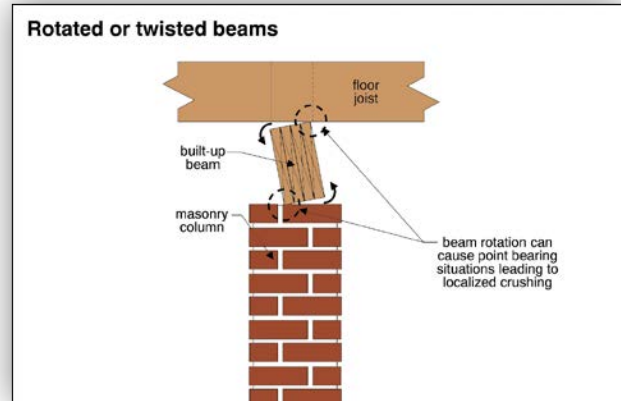

**SECURING TO POSTS** Steel beams may be poorly secured to posts. Wind uplift may cause the beam to lift off the post, or impact may shift it so that support is no longer offered. The beam and post should be bolted, welded or clipped together. In hurricane or earthquake areas, additional fastening may be necessary. Special straps are used to accomplish this.

**STRENGTH** A visual inspection of a steel beam cannot determine its strength because it depends on more than size. The shape of the beam, the length and thickness of both the flanges and web, and the weight per linear foot, all influence beam strength. The carbon content of steel also affects its performance.

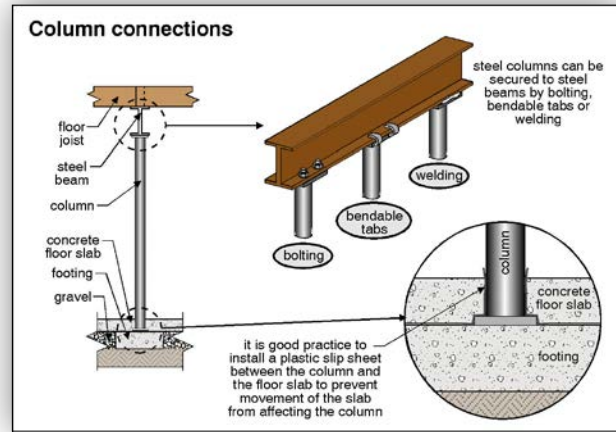

**STEEL VERSUS WOOD** Steel beams can be much stronger than wood beams and are more resistant to rot, insect and mechanical damage, but are more expensive, heavier, and more difficult to work with. Engineered wood beams can be stronger than solid wood, yet are light, easy to work with and less expensive than steel. Wood beams can be cut on site more easily than steel. Steel beams should rest on steel posts or masonry. Wood beams can rest on wood members.

**FIRE** Fire is a concern with both wood and steel beams. Interestingly, a steel beam will lose its strength much earlier in a fire than a wood beam, although a wood beam burns and a steel beam does not. Steel loses its strength after being exposed to temperatures of 1000° F. for about four minutes. Steel beams sag like spaghetti during a fire, allowing buildings to collapse quickly. Wood burns but loses its strength much more slowly.

### 5.3 Posts and Columns

**DESCRIPTION** Posts or columns (two names for the same thing) carry the load of the beam vertically down to the footings. They may be brick, concrete block, poured concrete, wood, or steel.

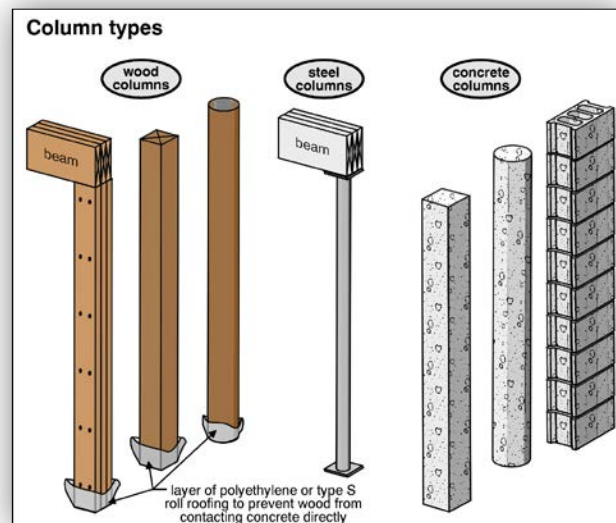

## Common Problems with Posts and Columns

- SPALLING/ MORTAR DETERIORATION** Masonry posts may be deteriorated as a result of moisture or poor mortar. Rising damp is a common problem with brick columns. This is characterized by deteriorated mortar and efflorescence (white salty deposits) on the bottom of the post. In some cases, the brick itself deteriorates (spalls).
- OUT OF PLUMB** Posts that are out of plumb lose a good deal of their strength. Generally speaking, if the column is out of plumb by roughly one-third of its thickness, there may be concern about its integrity.
- RUST** Rust on steel posts can be a concern. This is often a serious problem at the bottom of the post in a chronically flooding basement. Rust will quickly reduce the load carrying capacity of a steel post.
- ROT/INSECT DAMAGE** Wood posts are vulnerable to rot and insect attack. This is especially true where the post penetrates the basement floor slab. Corrective action often includes simply cutting off the bottom of the post and placing it on a concrete pad.
- FOOTING – MISSING OR TOO SMALL** A sinking post is usually the result of a missing or inadequately sized footing. Obviously, suitable footings should be provided. Every post or column should have a footing. These can't typically be seen once the home is built.
- UNDERSIZED OR DAMAGED** Column collapse is somewhat unusual but is normally the result of an undersized column or one that has suffered mechanical damage.
- NOT WELL SECURED TO BEAM** A post that is not well secured to the beam above can allow the house to shift during wind uplift forces. The beam should also be supported laterally to prevent it from moving sideways. See Section 5.2.

## 5.4 Floor Joists and Trusses

The function of these framing members is to carry and transfer loads from the floors to the foundations, beams or bearing walls.

**DESCRIPTION** **5.4.1 Conventional Wood Joists:** Joists are traditional dimensional lumber, typically 2x8, 2x10, or 2x12. These horizontal members can be 12 to 24 inches apart, although 16 inches is the most common. They are laid on edge so that the subflooring is nailed to the two-inch side. Floor joists should extend at least 1-1/2 inches onto the foundation or beam at either end.

**JOIST STRENGTH** The strength of a joist comes largely from its depth. Doubling a joist by putting another of the same size beside it will double its resistance to bending. Doubling the depth of a joist increases its resistance to bending by eight times! For example, the equivalent strength (considering deflection only) of two 2x10s compared to four 2x8s can be compared by multiplying the base times the height cubed. It is interesting that two 2x10s are more resistant to bending than four 2x8s.

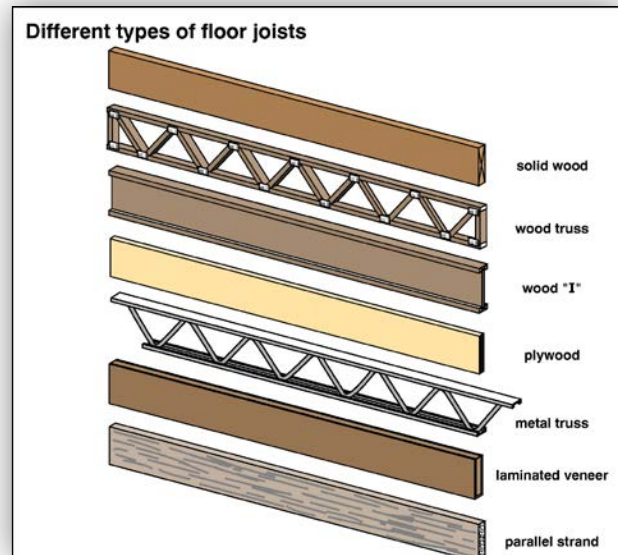

The deflection of a floor and joist system in modern construction may be quite surprising. Many codes allow a floor to deflect 1/360th of its length under normal loading if there is a finished ceiling below. For example, the following situation is acceptable by many codes: 2x10 floor joists spaced 16 inches on center span about 15 feet. When the room is occupied with furniture and people, the center part of the floor can be 1/2 inch lower than the floor edges. This is completely safe, and the floor is not at risk of failing. However, this may not be satisfactory to some homeowners. Codes are a minimum standard. Brittle floor finishing materials like ceramic tile may not tolerate a flex like this. More rigid floors are often used where the flooring material is brittle.

**SPRINGY OR BOUNCY FLOORS** Floors are often bouncy or springy when people walk across a room, but this is not necessarily indicative of problems. Light framing causes this condition, and while the floor can be stiffened, this is rarely done.

## Common Problems with Conventional Wood Joists

**OVER SPANNED** Floor joists that are over spanned (undersized) are prone to sagging. The acceptable span of a joist is determined by the load it will carry, the species and grade of lumber used, the depth of the joist, and the spacing between joists. Over spanning can be readily corrected by adding joists, or adding a beam below the joists in most cases. The implication of over spanning is typically a noticeable sag, and in some cases, a bouncy floor system.

**DAMAGE/ NOTCHED/ DRILLED** Mechanical damage to joists is common. Joists are commonly notched, drilled and cut through to accommodate heating, plumbing and electrical systems. In some cases, joists are cut around stairwells to improve headroom. Some damage is typical, and there are several guidelines on acceptable limits. Joists are sometimes notched at the end to rest on a beam or foundation wall. This can weaken the joist considerably. The joist usually cracks horizontally from the top of the notch towards the mid-point of the span.

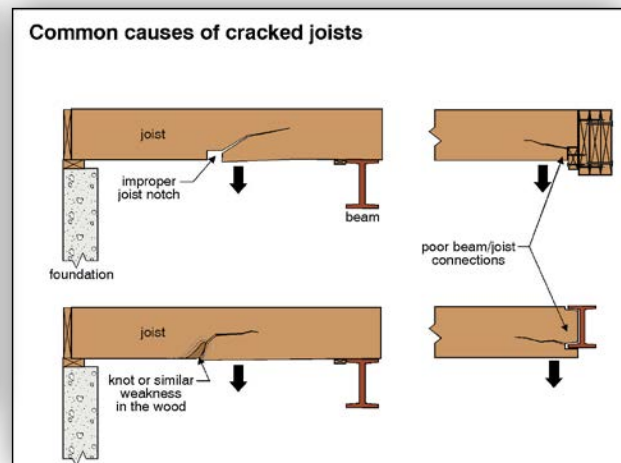
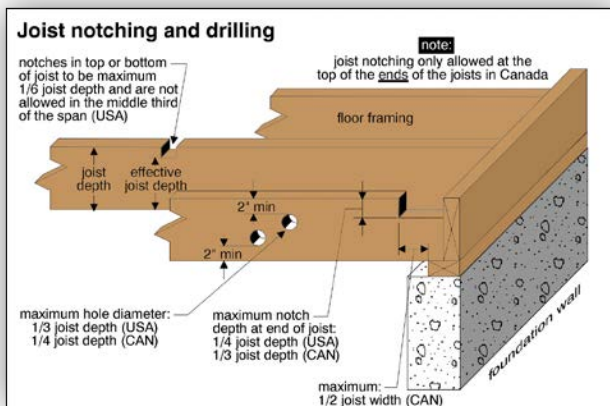
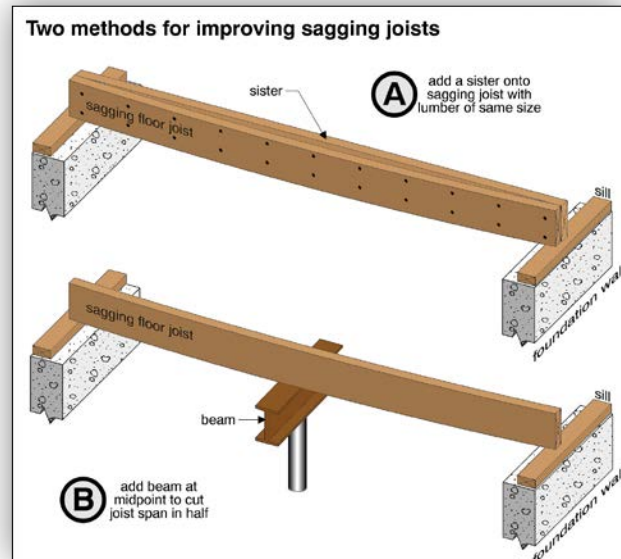

**INADEQUATE END BEARING** Joists may be prone to crushing at the ends and/or slipping off the beam or foundation where there is less than 1-1/2 inch of end bearing.



**JOIST HANGER** Metal brackets called “joist hangers” are used where joists cannot rest on a support. Here, the joists are cradled in and nailed to the hangers, which are secured to the side of a beam or header. Joist hangers may be undersized or inadequately nailed.

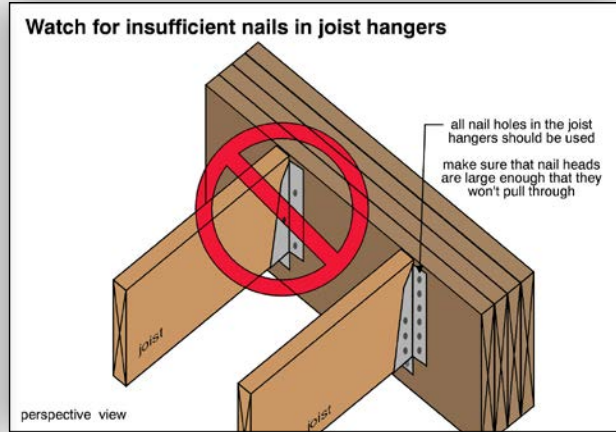
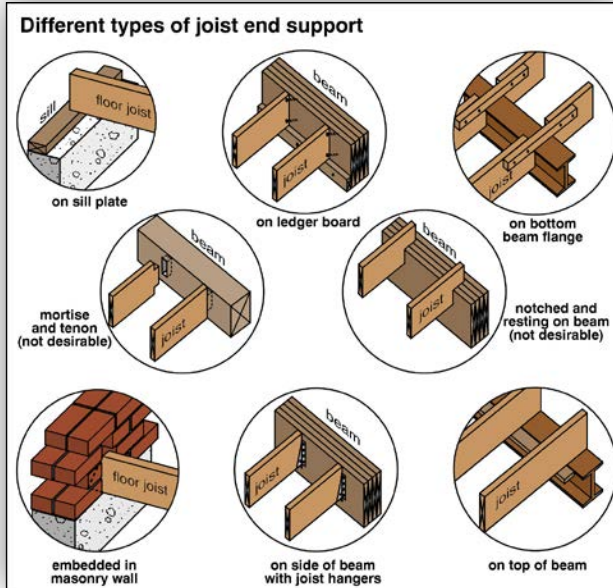

**ROT/ INSECT DAMAGE** Rot and insects can attack any wood components. Joist ends close to outside walls are vulnerable, especially if the outside soil level is as high as the joists.

**SAG – CONCENTRATED LOADS** Most floors are designed to carry live loads of 30 to 40 pounds per square foot (psf). Larger loads can lead to sagging and ultimately, failure. Special consideration may be needed for pianos, waterbeds, aquariums, and floor-to-ceiling book storage, for example.

**SAG – JOISTS BELOW WALLS** Joists that see concentrated loads are more prone to sagging. A joist below a non-bearing wall should be strengthened, often by doubling it. Joists should not be used below load-bearing walls. Beams or bearing walls should be used here.

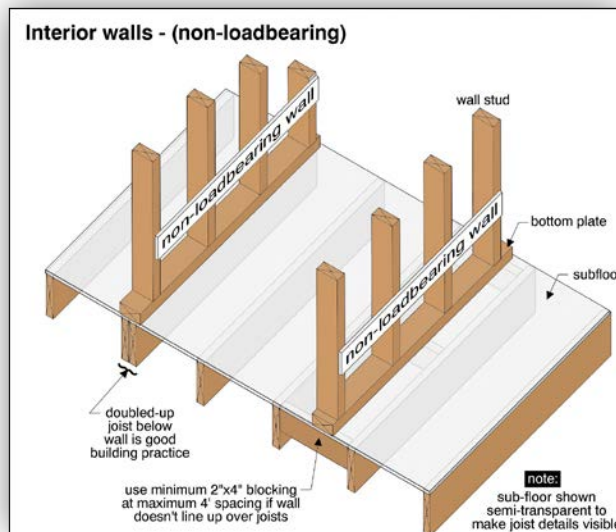

**SAG/HUMP – OFFSET BEARING WALLS** One of the problems often unfairly blamed on joists is caused by an offset bearing wall. Many houses have a beam or a bearing wall in the basement or crawlspace supporting the first floor. There is often a bearing wall above, supporting the second floor or roof structure. Ideally, the first floor wall is directly over the beam or wall below. If the wall is offset enough (sometimes 12 inches is enough), the joists will sag under the first floor wall above. This will lead to a low spot in the floor where the wall sits and a hump in the floor above the beam or bearing wall below. This sort of movement is rarely dangerous but it does make some people uncomfortable.

**DESCRIPTION** **5.4.2 Engineered Wood Joists:** Engineered joists may have conventional lumber top and bottom plates, or the top and bottom plates (flanges) may be LVLs (Laminated Veneer Lumber), PSLs (Parallel Strand Lumber), or LSLs (Laminated Strand Lumber). Webs may be plywood, oriented strandboard (OSB) or metal.

LVLs, PSLs, and LSLs can also be used as joists, beams, sills, headers (lintels), columns, studs, rafters, etc. Glulams (glue laminated lumber), made up of conventional lumber pieces glued together, can also be used for many wood structural members.

These systems have much longer spans than conventional lumber, and are less prone to shrinkage and warping problems than conventional lumber. The rules for engineered wood are different than for conventional joists, and some of the rules are specific to individual manufacturers. As always, a home inspection is a visual evaluation of field performance rather than a design analysis.

### Problems Specific to Engineered Wood Joists

- DAMAGE** Mechanical damage is common. Joists are notched, drilled and even cut through to accommodate heating, plumbing and electrical systems. In some cases, joists are cut around stairwells to improve headroom. Holes may be too big or in the wrong place (many systems have knock-outs that indicate where the holes must be). Split, notched or cut flanges may be a problem. The top and bottom flanges of wood I-joists (as engineered wood joists are often called) and trusses are critical. Any weakening will seriously affect the strength of the system.
- INADEQUATE END BEARING** Inadequate end bearing is a problem. More end bearing than conventional joists is often required. 1-3/4 inches is a common minimum.
- JOIST HANGER PROBLEMS** Metal hangers called “joist hangers” are used where joists cannot rest on a support. Here, the joists sit in the hangers, which are secured to the side of a beam or header. Joist hangers may be too short, too wide, the wrong type, and may not have enough nails or may have the wrong kind of nails.
- RIM JOIST ISSUES** Proper rim joist material may not be used. Engineered wood may require 3/4-inch plywood or special rim joist materials. Rims should not be conventional lumber. Inadequate load transfer through rim joists is a common problem.
- SQUASH BLOCKS MISSING/INCOMPLETE** Blocking (squash blocks or web stiffeners) may be missing or incomplete where joists rest on beams or where loads from bearing walls above are transmitted down through engineered wood joists to beams or sills.



**BRIDGING MISSING/INEFFECTIVE** Inadequate bridging or load sharing can be a problem. Different systems have different requirements for bridging.

**DESCRIPTION** **5.4.3 Floor Trusses:** The top and bottom horizontal members are called “chords”. The shorter interior pieces are referred to as “webs”. They are made from wood, steel and/or plywood. Trusses can span greater distances than conventional wood joists. Beams and posts or bearing walls can be omitted or removed with the use of floor trusses. These systems also allow heating, plumbing and electrical systems to run through the trusses, leaving more headroom below. Trusses do not normally require bridging or bracing.

Trusses are deeper than joists and can restrict headroom in some cases. As a general guide, the truss depth is 1/12 to 1/20 of its span. Most trusses are 10 to 18 inches deep.

### Common Problems with Floor Trusses

**UPSIDE DOWN** Many trusses have a top and a bottom, and must be installed in the correct orientation. A truss installed upside down is considerably weakened.

**CUT** Trusses cannot be cut around openings, the way joists can. Conventional joists can be field cut to appropriate lengths. A truss cannot be cut. All odd-length trusses must be engineered. Site conditions that are not foreseen or last minute plan changes, can lead to wasted money and delays, when working with floor trusses.

**SPAN** Trusses may be overspanned just like joists. These engineered systems can only be evaluated in the field by their performance. Home inspectors do not review the design of engineered systems like trusses.

**DAMAGE/ROT/INSECTS** Wood floor trusses are vulnerable to mechanical abuse, rot and insects.

**DESCRIPTION** **5.4.4 Headers and Trimmers:** Headers and trimmers strengthen an opening in the floor joist pattern for a stairwell or chimney. Also, basement windows often prevent floor joists from resting on the foundation walls and these openings in the framing pattern must be strengthened.

Normally, joists that cannot rest on a wall or beam are secured to a header. A header is typically made of the same size lumber as the joists (e.g. 2x8s). The header, which runs perpendicular to the joists, carries the load from the short joists (tail joists) over to trimmer joists. Trimmer joists are the joists on either side of the opening that run full length.

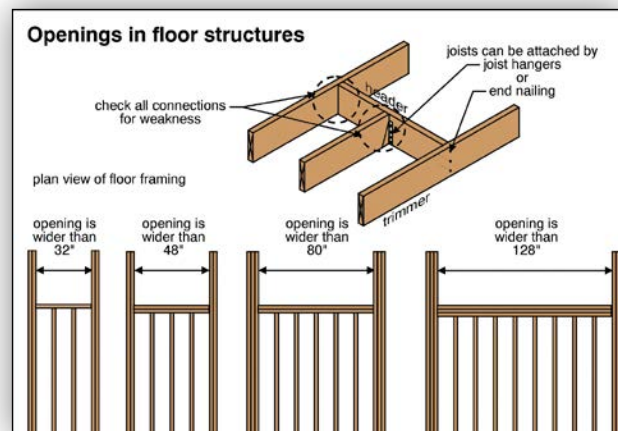

**POSTS** Posts can be provided at the corners of the opening to carry load from the header directly down to the floor. In this case, the trimmers could remain single. The header can also be supported with a bearing wall running under the header.

### Common Problems with Headers and Trimmers

**UNDERSIZED/NOTCHED** Undersized trimmers and headers are common. It is also common to have the trimmer notched at the bottom of the stairwell to improve head room. This, of course, weakens the arrangement.

**POOR CONNECTION** The short (tail) joists may be poorly secured to the header. Joist hangers (metal brackets) can be used to re-secure these tail joists. Headers may also be inadequately secured to the trimmers. Again, joist hangers can be used.

**ROT/INSECT DAMAGE** Rot and insects can weaken the stairwell opening framing.

**DESCRIPTION** **5.4.5 Bridging and Blocking (and Strapping):** Bridging/blocking prevent the joists from twisting. Diagonal bridging is usually 2x2 wood blocks or metal strapping. Solid blocking is the same size as the joists. To be effective, the bridging or blocking should be in a straight line and should extend the full length of the floor.

Solid blocking is required at the ends of joists. Tall joists require bridging or blocking at least every eight feet. More blocking may be needed where earthquakes are a risk.

**DESCRIPTION** **5.4.6 Cantilevers:** Floor joists may be cantilevered (extended) slightly beyond their supports. A common example is a balcony. This is often done on an upper floor, where support posts would be expensive and unsightly. The principle is that since wood is relatively stiff, if part of a joist is well secured at one end and part way along its length, the other end can be unsupported. Roughly 1/6 of the joist span between supports can be usually be cantilevered safely beyond a support.

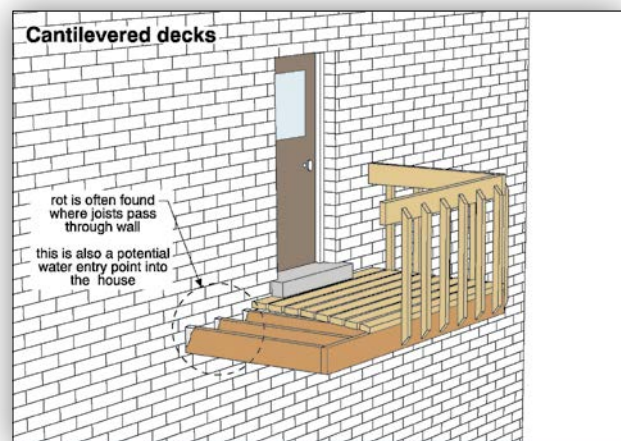
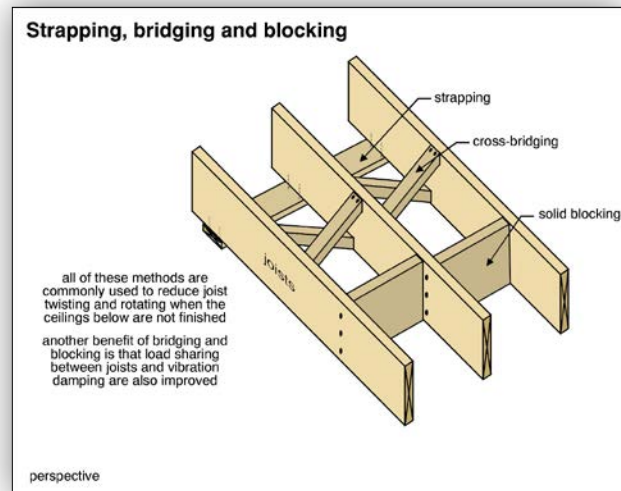

## Common Problems with Cantilevers

**OVERSPANNED** Where the joists are cantilevered too far, the deck or balcony will be weak. This is usually detectable by the springiness of the structure when walking on it. In severe cases, failure is possible. Posts or braces can be added below the deck.

**WATER PROBLEMS** Since the joists penetrate the building wall, there is the possibility of leakage into the walls or directly into the home at the connection points. The joints between the joists and the wall must be kept well sealed. This is a common spot for rot to develop, attacking both the cantilevered joists and the wall structure.

**ROT/INSECT DAMAGE** Cantilevered wood structures are susceptible to rot and insect damage.

**DESCRIPTION** **5.4.7 Steel Floor Framing:** Structural framing elements are generally either C-shaped or U-shaped steel components. C-shaped elements are designed as load-bearing elements, such as joists, while the U-shaped pieces are tracks, or channels, designed to hold the load-bearing components in place.

Steel framing members are normally screwed together, although they may also be welded. Members may be screwed directly to each other, or clips (clip angles) may be used to join members together, with the clip being screwed to both elements. Screws are also used to join wood framing, sheathing, and drywall finished to steel framing. Securing joists to steel beams requires the use of clips and powder-actuated fastener guns.

**BEARING STIFFENERS** Bearing stiffeners (web stiffeners) are required where a concentrated load, such as a door jamb, rests on a floor joist. These usually take the form of a section of stud or track mounted vertically on either side of the joist below the point load. Web stiffeners are also required where the joist rests on a load bearing beam or wall.

**HOLES/NOTCHES** Steel floor joists usually come with pre-punched holes for plumbing and electrical wiring, and should be installed so that these holes are aligned for easy installation of the mechanical and electrical systems. There are industry-specified requirements for other holes. Joists should not be notched.

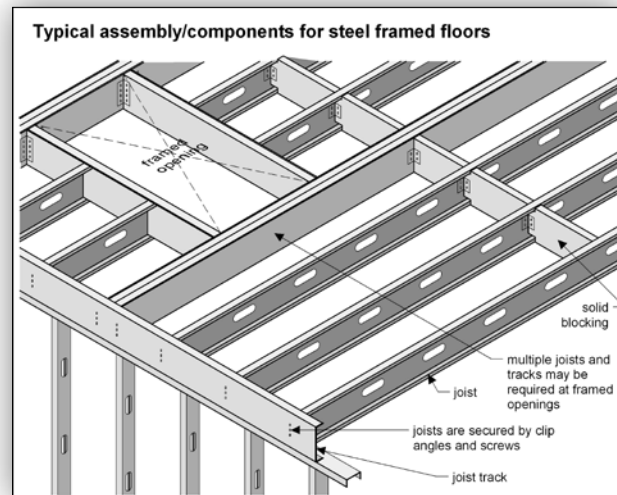

**BRIDGING/ BLOCKING** Floor joists will twist and bounce under load if the tops and bottoms are not properly braced. The top is typically braced by the flooring. The bottoms can be braced with a drywall ceiling for example. Where there is no ceiling, the joist bottoms should be braced every 12 feet. This can be X-bracing, flat straps along the undersides and/or solid blocking.

**FRAMING AROUND STAIRS AND CHIMNEYS** When the joist pattern is interrupted by openings for stairwells and chimneys for example, reinforcing with headers and trimmers is required, in much the same way it is done with wood framing.

### Common Problems with Steel Floor Framing

**RUST/ CORROSION** Steel framing members in contact with moisture for a prolonged period of time will corrode. This may be an issue in below-grade areas or below roof or plumbing leaks.

**OVERSPANNED** The span of a steel floor joist depends on its height, width and the gauge of steel used. While there are general guidelines, individual manufacturers have specific requirements.

**POOR CONNECTIONS** Weak screw connections can be an issue with steel framing.

**CONTACT WITH OTHER MATERIALS – DETERIORATION** Steel reacts with copper plumbing for example, and should not be in contact with dissimilar metals. Unless special consideration is given, steel framing should not be embedded in concrete.

## 5.5 Sub-flooring (Also called Floor Sheathing)

**DESCRIPTION** Sub-flooring transmits the live loads of the people and furnishings to the floor joists. Sub-flooring may be covered with a finish flooring material or may serve as a finish flooring itself. One-inch thick wood boards were used as sub-flooring until roughly the 1960s. More recently, plywood and waferboard have been used. Thin concrete subfloors are less common.

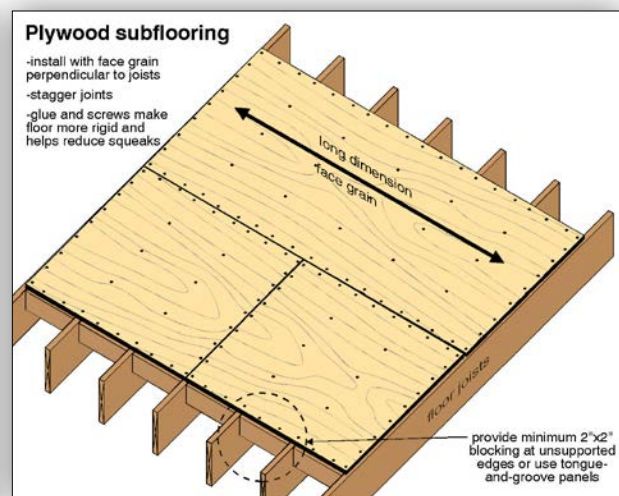
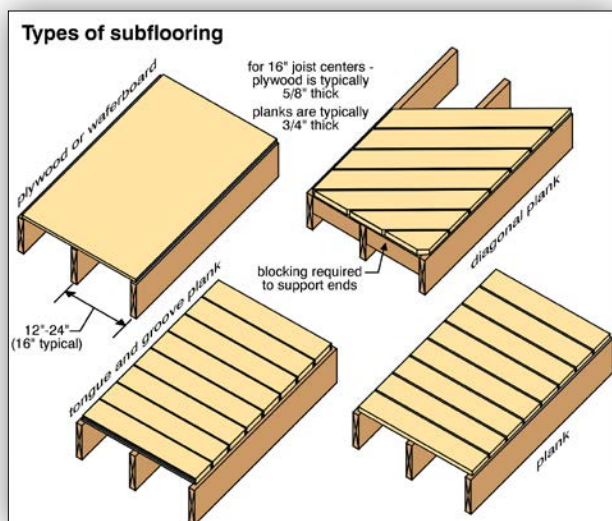

## Common Problems with Sub-flooring

**SPRINGY FLOORS** Subflooring that is too thin will be springy and may fail under concentrated loads (e.g. a piano). This should be overlaid to provide a stiffer subfloor.

**SQUEAKY FLOORS** Subflooring not adequately secured to the floor joists may be squeaky. The weight of someone walking on a floor will temporarily push the subfloor down onto the joist. When the foot is removed, the subfloor will lift off slightly again. The noise is the nails squeaking as they slide in and out, or pieces of wood rubbing against each other. Solutions to this nuisance include re-nailing, screwing and gluing the subfloor to the joists.

**WATER DAMAGE** Waferboard subflooring can be damaged by relatively small amounts of water. The board tends to swell, resulting in floor unevenness. The swelling also pulls the nails out of the joists or through the waferboard. Ultimately, the board can lose its strength.

**EDGE SUPPORT** Diagonal plank subflooring must be supported where it meets the wall. The ends of some of the planks may be several inches from a floor joist and if adequate blocking is not provided, the floor will be weak in this area. Where plywood or waferboard subflooring sheets meet, the joint should be supported by joists, blocking or tongue-and-groove connections between the sheets.

**DAMAGE** Any subflooring can be mechanically damaged and, unless repairs are made, this can lead to an unsafe situation. A common problem is a hole cut for a heating register that was never installed. If carpet is laid, this may not be noticed until a furniture leg is put on the weak spot. Repairs are, of course, simple and inexpensive.

**UNEVEN** Uneven subflooring can be a nuisance. Uneven joist installation is a common cause, as is debris on the top of the joists when the subfloor is laid. Swollen waferboard or delaminated plywood can also result in unevenness. Careless joining of tongue-and-groove sheets can lead to surface irregularity.

**ROT/INSECT DAMAGE** Subflooring is susceptible to rot and insect damage.

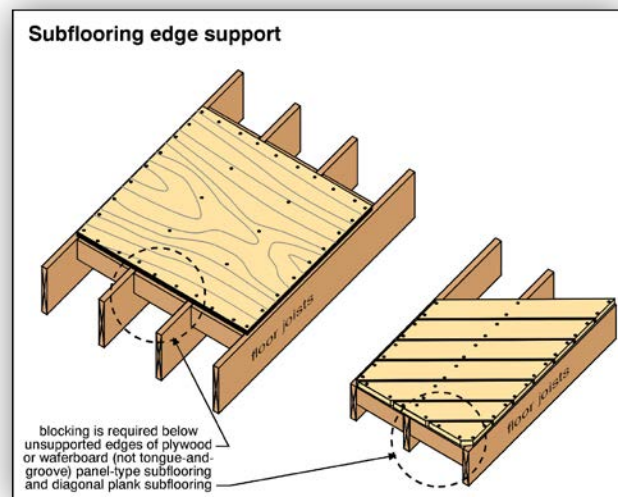



## 5.6 Concrete Floors

**DESCRIPTION** Concrete floors in homes with basements are usually not structural. Basement and garage floor slabs rest on the ground and are usually poured after the house is built. Modern floors are typically three-inch thick slabs, although old ones may be as thin as 1/2 inch.

Slab-on-grade homes may have concrete floors that are part of the structure.

### Common Problems with Concrete Floors

**CRACKED/  
BROKEN** Floors may be cracked or broken. Replacement is not a priority, but is often done to make a basement or garage more usable. Broken utility lines are a possibility with slab movement on slab-on-grade homes. The movement may be settlement or heaving due to expansive soils, for example.

**NO SLOPE TO  
DRAIN** Many basement and garage slabs do not slope to drains. Re-sloping is rarely done because it is expensive and the problem of water on a floor is rarely serious.

**SUSPENDED  
SLABS** Suspended concrete floors are not common in homes. One exception is concrete porch slabs above cold cellars.

Suspended concrete floors above grade are common in high-rise and commercial buildings, and use steel reinforcing. They are heavier and more expensive than conventional wood floors, but can also be stronger and are more fire resistant. Suspended concrete floor systems are not evaluated during a home inspection.

## 6.0 Wall Systems

Walls carry the weight of the roof and floors down to the foundations, as well as providing a separation between inside and outside. Walls keep out the wind, rain, heat, cold, and noise, as well as providing us with privacy and support for interior and exterior finishes.

After a home is built, it may be difficult to identify the wall construction.

### 6.1 Materials

**DESCRIPTION** **6.1.1 Masonry Walls:** Common materials include brick, stone, concrete block, cinder block, clay tile and glass block. Masonry walls are typically comprised of two four-inch thick wythes (layers) of masonry. The outer wythe is often weather-resistant brick or stone. The inner wythe (layer) may be lower quality brick, concrete block or cinder block. The foundation must be wide enough to carry both layers of masonry.

Mortar used to bind masonry units together is a combination of cement, sand, and water. For more information on brick and mortar, see Section 3.2 in the Exterior chapter.

The masonry units may be exposed or covered with stucco, for example.

**IDENTIFICATION** In most cases, a solid masonry wall can be identified by the header courses (rows where the brick is turned end-wise to lock the inner and outer wythes of the wall together). This is done every five to seven courses (rows) up the wall. Sometimes every brick in the course is turned end-wise. Often, only every other brick is turned, and sometimes the pattern is random. In most cases, however, there are at least some of the units that are turned in every fifth, sixth or seventh course.

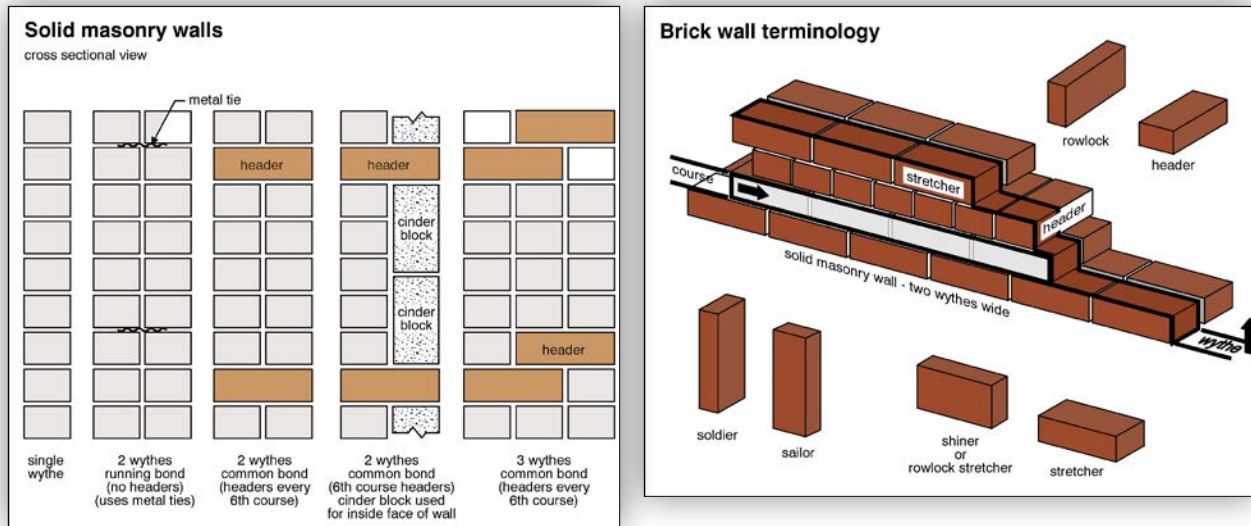

Metal ties or specially sized bricks can also be used to join the inner and outer wythes. In this case the wall will show no header courses, and it will not be apparent that it is a solid masonry wall.

Solid masonry walls have not been commonly used on single-family homes in many areas since the early 1970s. Areas prone to hurricanes are an exception.

### Common Problems with Masonry Walls

**DETERIORATED** The wall may be weakened if the masonry or the mortar deteriorates. This may be the result of poor quality masonry or mortar, chronic moisture exposure or freezing.

**CRACKS** Cracks in brickwork may appear for several reasons. Cracks are clues, and their size, location, direction and rate of growth are all indicators of what is happening. Generally speaking, cracks through mortar joints are less serious than cracks through the brick or block, but there are exceptions.



**LEAN/BOW** Where the inner and outer wythes are not adequately secured together, the outer wythes can lean or bow outwards. The entire brick wall may lean or bow due to foundation settlement or the wall not having adequate lateral support. Walls may also be pushed out of plumb by vehicle impact, for example. If a wall leans, the ultimate danger is that it may fall. The more immediate danger, however, is that the rafters and joists resting on the wall may slip off as the wall moves out away from the building. Since the ends of joists may only rest on the wall by an inch or two, a little movement can create an unsafe situation. If joists or rafters slip off their supports, the framing system will collapse.

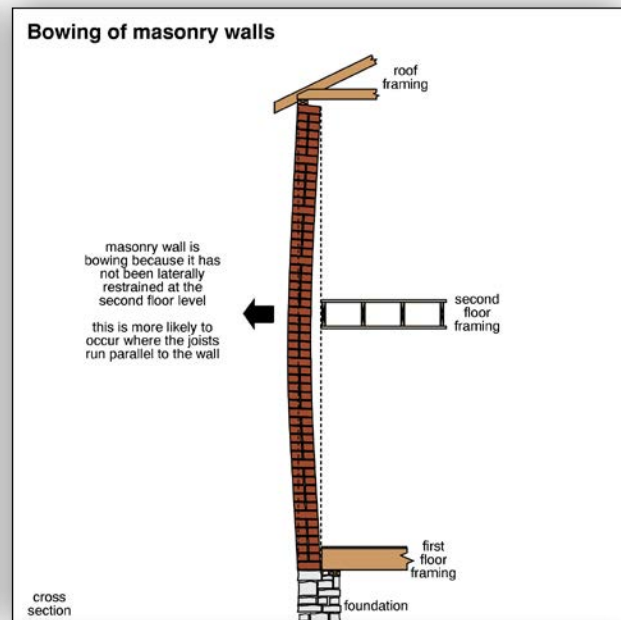
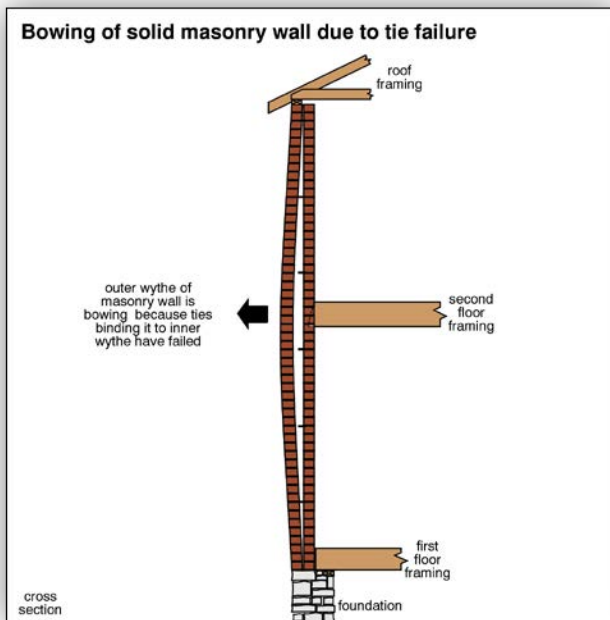

**RAFTER SPREAD** Spreading roof rafters may push the top of the walls out, resulting in an unstable situation.

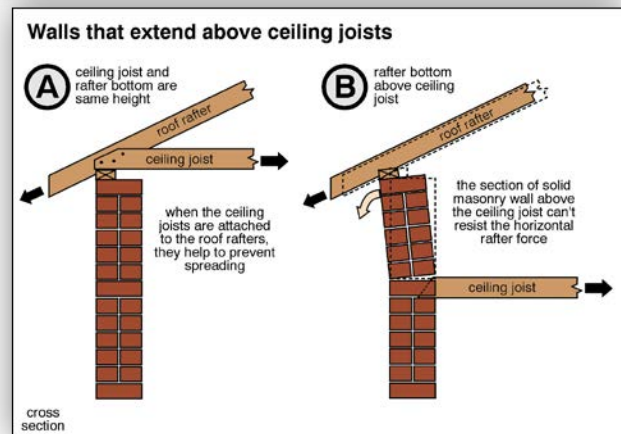

**EXCESS CORBELLING** Brick can be corbelled (offset) only about one inch beyond the brick below (i.e. one brick does not have to be set exactly on top of another). However, the total corbelling must not exceed one-third of the wall thickness to maintain stability.

**DESCRIPTION 6.1.2 Wood Frame Walls:** Load-bearing wood frame walls may be interior or exterior walls.

Some stud walls are load-bearing, others are not. Bearing walls should have a double top plate. Non-bearing stud walls may have only a single top plate.

A single sole plate (also called sill plate or bottom plate) is provided in either case. None of this is visible once the home is finished.

Historically, 2x4 studs have been used, spaced 16 inches on center, although more recently, 2x6 exterior wall studs have become common as they provide more space for insulation between the studs.

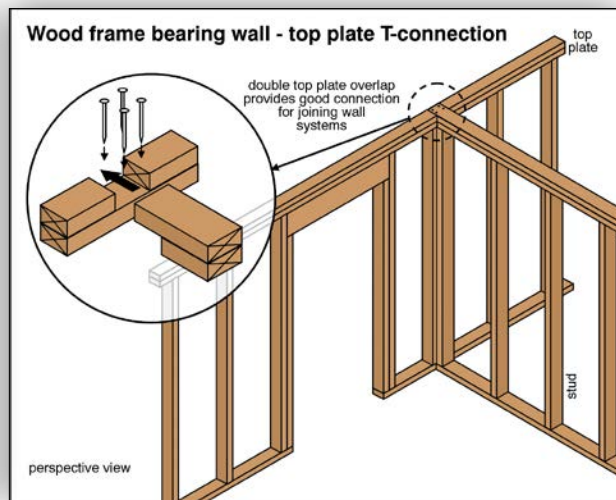
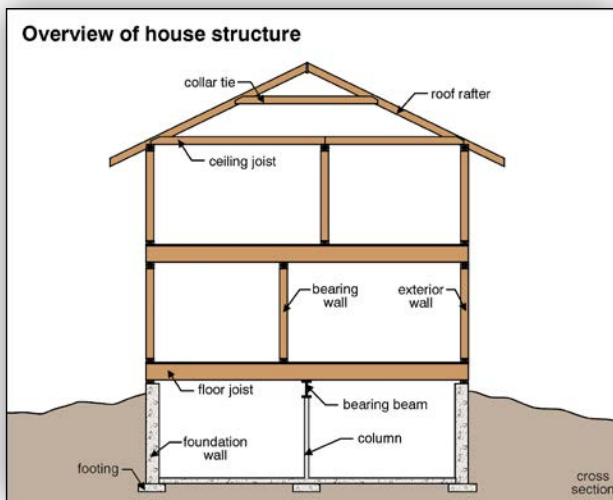
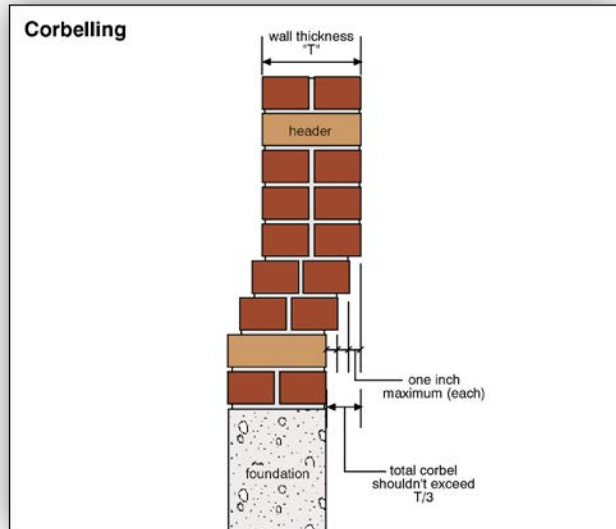

## Common Problems with Wood Frame Walls

Rot, insect attack, mechanical damage, poor quality lumber, poor connections, design mistakes, poor workmanship and excessive spacing can all be problems.

**POOR NAILING AND OPENING** Inadequate nailing can lead to difficulties. Openings in walls may not be adequately framed. Wall sections above large openings for picture windows, for example, may sag if the openings are not bridged with appropriate support headers (some call these lintels).

**NOTCHES AND HOLES** Holes and notches can weaken studs if they are too large. The illustrations below provide some guidelines.

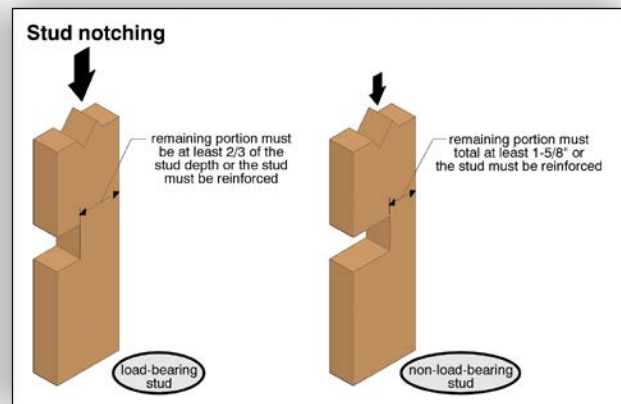
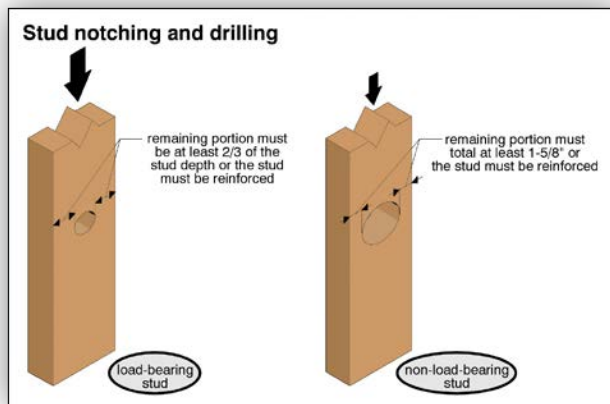
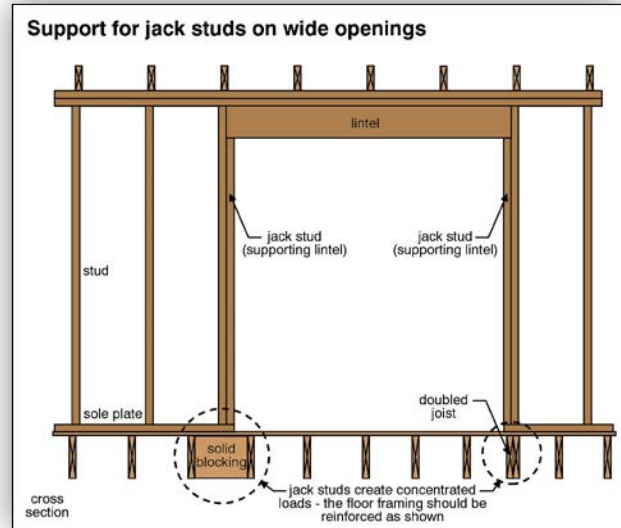

**BUCKLING** Some wood stud walls are susceptible to buckling under loads. This is particularly true if the walls are not braced with girts (blocking between studs near the mid-point) or if interior or exterior finishes are not provided. If finish is provided on one side of the wall, girts are not required.

Longer studs are more susceptible to buckling. This is easy to understand if you hold both ends of a yardstick and try and push the ends toward each other. The yardstick buckles very easily in the middle. This is more difficult with a six-inch ruler of the same material.

Where another floor level is to be added to a home, special consideration should be given to stud walls, which may not be strong enough to carry the added weight.

**CONDENSATION IN COLD CLIMATES** Rot or mold caused by condensation in exterior walls is a concern, especially where insulation is upgraded in older houses, and without effective air/vapor barriers. This cannot be detected during a visual inspection and it may be a long time before the damage is noticed. In some cases, peeling exterior paint suggests that wall condensation is a problem.

This is typically a seasonal problem in cold climates, with the condensation occurring during the winter months only. Warm moist air enters the wall from the house. As it passes through, the air cools. Cool air cannot hold as much water vapor as warm air. Condensation forms inside the wall as the air cools and gives off its water.

**LOW QUALITY LUMBER** Poor quality studs or studs that warp and bow can lead to uneven wall surfaces in new homes. The bowed or twisted studs have to be repaired or replaced.

**GREEN LUMBER** Building with lumber that is too wet or “green” can result in problems such as shrinking, warping, or bowing.

**DESCRIPTION 6.1.2.1 Balloon Framing:** Balloon framing was common in the late 19th and early 20th centuries. This wood-frame construction technique used conventional studs and floor joists. However, the wall studs were continuous from the foundation up to the roof line. The construction process involves setting up the wall studs, and then hanging the floor systems from them. When completed, this resulted in a rigid structure. One disadvantage is that a fire can move very quickly up through the continuous stud spaces.

**DESCRIPTION 6.1.2.2 Platform Framing:** Platform or Western framing is slightly different. A wood floor joist and subfloor system is provided on top of the foundations. One-story stud walls are built on the floor. If the house is two stories, a second floor platform is assembled on top of the studs, and then a second stud wall is built on top of this platform. This can be extended up to form a three-story house as well. The advantages of platform framing are ease of installation and lower material costs.

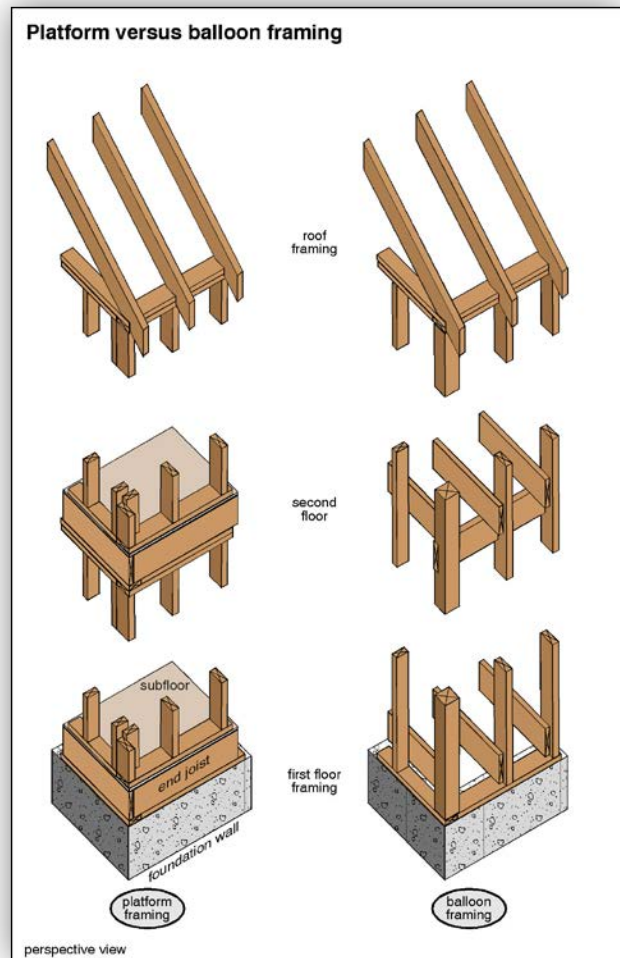

**DESCRIPTION 6.1.3 Steel Frame:** Steel frame walls may be load-bearing, carrying the weight of the roof and floors down to the foundations. They may be interior or exterior walls. Steel frame walls may also be used as non-load-bearing partition walls. While wood framing members have traditionally dominated residential construction, the use of lightweight steel framing is increasing.

Structural framing elements are generally either C-shaped or U-shaped. C-shaped elements are designed as load-bearing elements, such as studs and joists, while the U-shaped pieces are tracks, or channels that hold the load-bearing components in place. In steel construction, tracks replace the sills and top plates used in wood-frame construction. Non-load-bearing walls are typically thinner, but are otherwise similar to load-bearing walls.

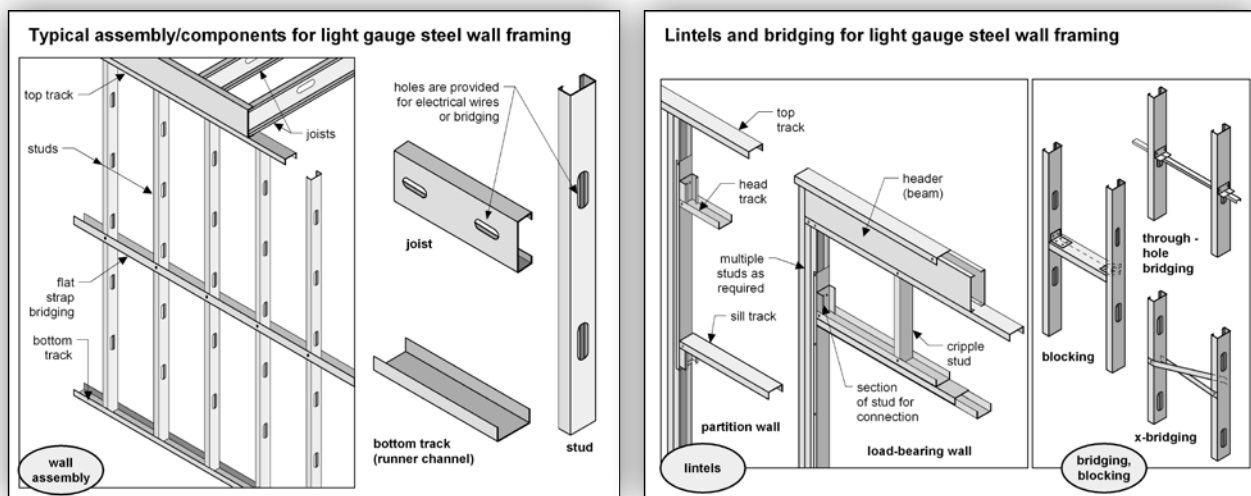

### Common Problems with Steel Frame Walls

- THERMAL BRIDGING** As steel is much more conductive to heat than wood, the thermal efficiency of steel-framed walls is much less than that of a wood-framed wall. Steel framed walls may have half the insulating value of wood walls. The thermal bridges created by steel studs can be reduced through the use of insulated sheathing on the outside of the studs, and with the use of wider stud spacing.
- CORROSION** Some older steel frame walls did not adequately deal with thermal bridging issues, leading to condensation and corrosion of the steel studs. Corrosion may be an issue whenever there is a condensation or water leakage problem.
- IMPROPER HOLES** Steel studs usually come with pre-punched holes for plumbing and electrical wiring and should be installed so that these holes are aligned for easy installation of the mechanical and electrical systems. There are industry-specified requirements for other holes. Improper holes can weaken the wall.



**REINFORCEMENT MISSING/INADEQUATE** Wood nailing strips are often required to allow door jambs and other trim to be nailed to the framing. Finishing screws may be used instead of nails. Walls have to be reinforced in some areas, such as when cabinets are to be secured to non-load-bearing steel studs.

**DESCRIPTION 6.1.4 Brick/Stone Veneer:** A brick or stone veneer wall has a structural wood (or metal) frame inner wall, and a four-inch thick masonry outer section (veneer), which does not have any load-bearing responsibility. Typically, metal ties are used to secure the masonry to the wood frame wall, and there are no header courses in the masonry. The absence of headers identifies a veneer wall in most cases. Most solid masonry walls have headers.

Veneer walls have been the most common masonry walls in single-family homes in many parts of America since about 1970.

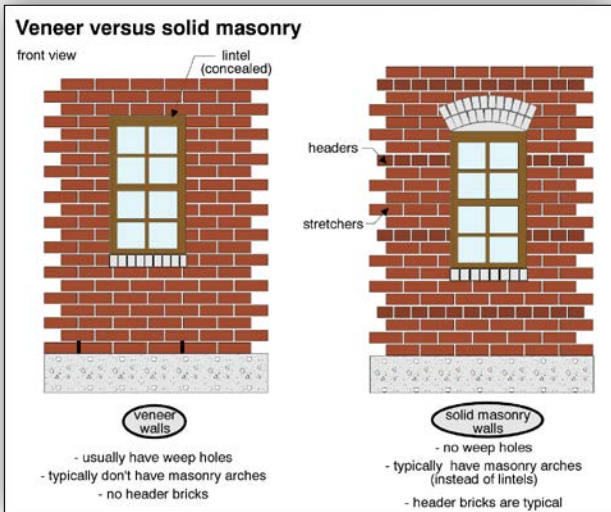
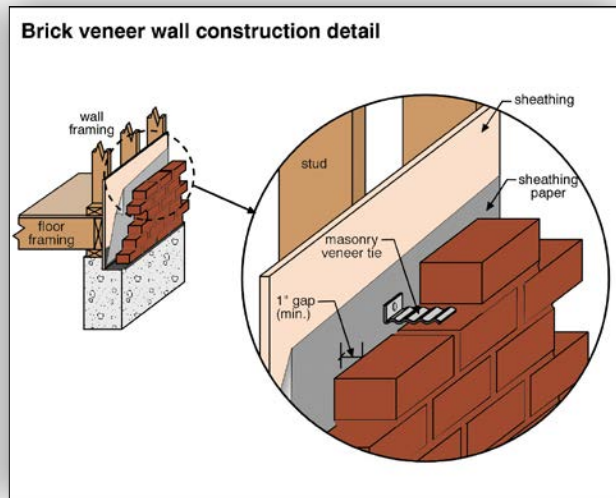
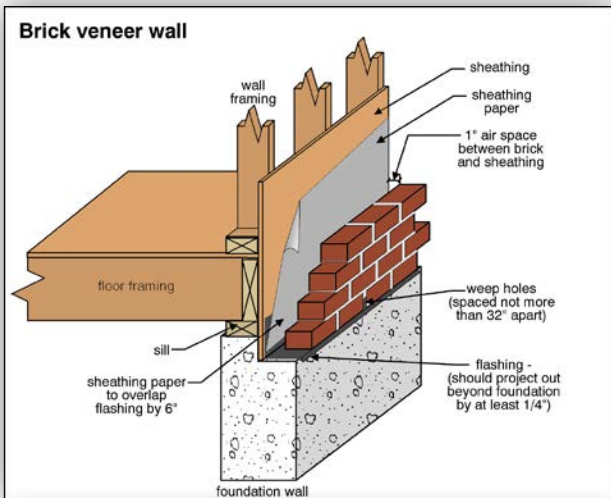



**RAIN SCREEN PRINCIPLE** Since the early 1970s, veneer walls have had weep holes provided at the bottom. A modern veneer wall uses a rain screen principle. This anticipates that wind driven rain will pass through a masonry wall, and as a result, a one-inch air space separates the masonry and the wood stud wall. Water runs down the inner face of the brick or the outer surface of the sheathing and drains out the bottom.

At the bottom row of masonry, every fourth vertical mortar joint (typically) is left open. A flashing at the bottom of the wall cavity directs water out through the weep holes. The flashing prevents the water from entering the foundation. Weep holes are also used above door and window openings.

Weep holes also allow pressure balancing on either side of the masonry. The air in the cavity behind the masonry is pressurized as wind blows against the wall, reducing the pressure differential across the masonry. This reduces the amount of water driven through.

A variation on weep holes is rope wicks in every fourth mortar joint in the bottom row of masonry. Where weep holes or wicks are noted, the wall is masonry veneer.

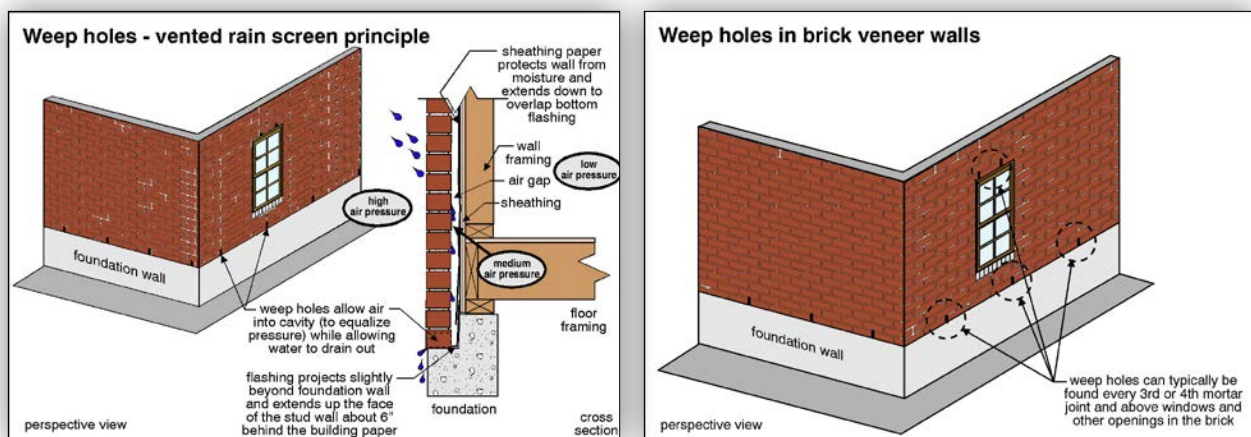

### Common Problems with Brick or Stone Veneer Walls

- FOUNDATIONS/ CONNECTIONS** Although the veneer has no load-bearing responsibilities, it must sit on a foundation built to support the weight of the brick or stone. If the foundation is not substantial, the veneer wall may crack and/or settle away from the wood-frame wall. If the veneer is inadequately tied to the wood-frame wall, the masonry may bulge or pull away. This is an unsafe condition.
- DETERIORATED** Deteriorated masonry or mortar can lead to serious problems. In the worst cases, the veneer wall has to be rebuilt. Most brick is not designed to be in contact with the soil, and should be kept well above grade.
- WEEP HOLES** If weep holes are filled or omitted, water can collect in the wall cavity, damaging the sheathing and studs.

**FLASHING** Similar results occur if the flashing is inappropriate or the space between the masonry and sheathing is filled. The flashing cannot normally be seen during an inspection.

**CORBELLING** Excessive corbelling can make a wall unstable. (See Section 6.1.1)

**METAL ANGLES** In some cases, the masonry veneer is supported on steel angles bolted to the foundation. If there is any movement at all, the masonry may crack, bulge, or pull away from the wall behind.

**DESCRIPTION** **6.1.5 Insulating Concrete Forms (ICFs):** Insulating Concrete Forms (ICFs) are either panels or interlocking blocks that are joined together to create form-work for concrete. The forms themselves are made out of insulation, either rigid foam, such as polystyrene, or a combination of concrete and foam insulation or wood chips. Plastic ties may be used to hold the inner and outer forms together. Once the forms are in place, concrete is poured into the forms, filling the spaces. Rather than remove the forms, as in conventional concrete work, they are left in place to act as insulation.

ICF walls are also used as foundation walls.

After a home is built, it may be difficult to identify the wall construction.

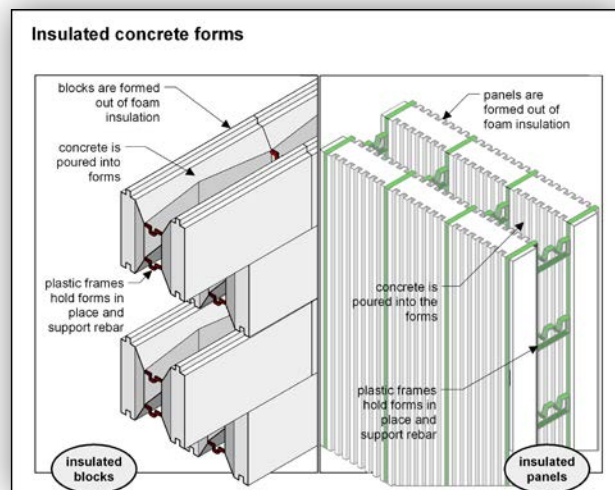
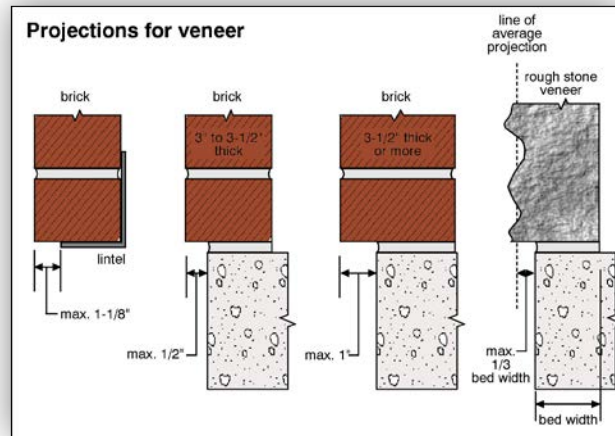
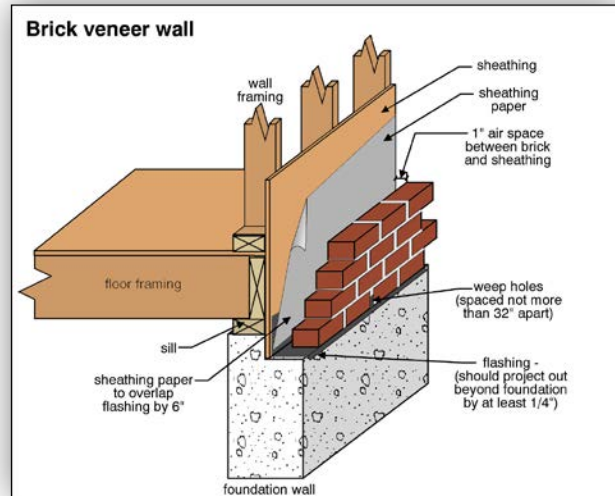

- INSULATION** ICF walls typically provide a total R-value of 22, about the same as a 2x6 stud wall. These walls also avoid thermal bridges (areas of high thermal conductivity) that are common in wood stud walls. ICF walls are also airtight, which is good for energy performance.
- REINFORCEMENT** ICF walls may include vertical and/or horizontal steel reinforcing bar, especially around window and door openings.
- LEDGERS** Where floors meet ICF walls, they may either rest on a sill plate on the top of the ICF wall, or bear on a ledger board secured to the ICF.
- OPENINGS** In most cases, wood framing is attached to the ICF at door and window openings to allow window frames and door jambs to be secured.
- ELECTRICAL WIRING** Electrical wiring and outlets generally require the inside form to be cut away. The shallow depth of the form means that wiring may require protection from mechanical damage, and receptacles need shallow boxes.

### Common Problems with ICF Walls

- WOOD DESTROYING INSECTS** While polystyrene is not a food source for pests, some wood-destroying insects will nest in, or travel through, the foam. Some ICF products contain chemical protection, and some ICF installations use mechanical barriers to protect against infestation.
- RENOVATIONS** It is more difficult to create a new opening or alter an existing opening in an ICF wall than a wood frame wall because of the poured concrete.

#### 6.1.6 Other Kinds of Walls

- DESCRIPTION** **6.1.6.1 Log:** Modern log homes utilize precisely cut logs, keyed together, with gaskets between logs, while older log structures are much rougher.
- SIDINGS** Many older log homes were covered with wood sheathing such as clapboard on the exterior as soon as the homeowners could afford it. Stucco was also used on the exterior in some cases and plaster was often applied on the interior. Some old log homes look quite different than they did when they were built. The foundations were typically stone, and wood shingles or shakes were often the roofing material.
- CHINKING** Chinking was traditionally used to fill the gaps between the logs. This was typically a mortar made of clay, sand and binders such as animal hair. Where gaps were large, stones would often be fitted in before the chinking was applied. Due to the considerable movement due to expansion and contraction of logs across the grain, chinking usually had to be redone every year, at least in part.

## Common Problems with Log Walls

**WOOD SHRINKAGE** Traditional log construction today is a relatively expensive way to build. Further, wood tends to shrink and expand with changes in moisture content much more across the grain than it does with the grain. A log wall grows shorter as the wood dries and taller when the wood is wet. A wood stud wall will shrink and expand much less because the wood grain is vertical rather than horizontal.

If wood changes its moisture content from 19% to 5% (typical in a house), its length may change by 0.1% along the grain, but its width may shrink by 2.5% across the grain. This means an eight-foot long stud may only shrink 1/10 inch, while a stack of logs eight feet high may shrink by 2-1/2 inches. This can be a significant problem with windows, doors and other building components attached to a log wall.

**CHINKING** Regular maintenance is required in chinking the gaps between the logs in traditional log homes. The modern materials now available perform much better.

**ROT/INSECT DAMAGE** Rot is a common problem with logs at the bottom of the wall (where they may have been in contact with earth) on old homes. This is not likely to be a problem with modern log houses built on conventional modern foundations. Log homes are susceptible to insect damage, of course.

**CONCEALED DAMAGE** Where the logs have been covered with siding, concealed water damage is possible.

**DESCRIPTION** **6.1.6.2 Post and Beam:** This type of construction, with wood members much larger than conventional wood-frame construction, is not common, although it can be found on older country properties and was commonly utilized for barns, mills, churches and other large buildings. There are prefabricated kits available. Other names for this type of construction include timber, heavy timber or semi-mill construction.

This building style uses a small number of large wood beams and posts. This is very different from conventional framing that uses a large number of smaller wood studs and joists to carry the loads down to the foundations.

Traditionally, the heavy posts and beams were solid wood. In homes built today, built up or glue-laminated beams and posts are also used. In the original versions, the heavy wood posts were often flared out at the top to increase strength. A feature of these homes was the way the wood sections were connected. Very sophisticated mortise and tenon connections were utilized, as were dovetail joints. Many of the homes were assembled without nails, wood dowels often being used in their place.

The walls were often 2-inch thick planks, installed horizontally or vertically. In some cases these were load bearing, although for the most part they simply provided a weather tight skin.

These houses were expensive to build both in terms of materials and labor. Large pieces of good quality lumber have become harder to obtain. Because the wood components were very heavy, and sophisticated joint connections were used, construction was labor intensive.

### Common Problems with Post and Beam Walls

- LACK OF RIGIDITY** Since the skeleton consisted of a few large components and relatively few connections, rigidity could be a problem, particularly where the sheathing did not perform a stabilizing function. Because of the intricacy of some of the connections, there was a good deal of room for error, and a poor understanding of load transmissions could lead to connection failures.
- EXPANSION/CONTRACTION** The very large timbers undergo significant dimensional changes with changes in moisture content. These buildings are not static, expanding and contracting with changes in humidity. As timbers dried out, checking often developed. Checks are longitudinal cracks, parallel to the grain that widen as they get further from the heartwood. In many cases, this is not a structural concern, although a large check running horizontally through a beam does reduce its load carrying capacity. Where continuous checking in a post could lead to buckling, steel clamps are provided around the posts.
- FOUNDATION** Because of the skeletal nature of the framing, large concentrated loads were carried to the ground. Foundation systems were often too weak in areas of concentrated loads, and much stronger than they had to be in other areas.
- CONNECTIONS** These buildings rely on relatively few connections. Poorly made connections or damage by rot or insects can be more serious than on frame construction.
- SPECIALIZED INSPECTION** Since this type of construction is specialized, and not seen frequently, local authorities and professional home inspectors may not be familiar with it. In some cases, a specialist is engaged to comment on post and beam structures.
- REPAIR** Repair or replacement of components of post and beam construction is often difficult without compromising the aesthetic or architectural appeal of the home. The strength of structural components must be demonstrated using engineering calculations, rather than tables.

**DESCRIPTION** **6.1.6.3 Panelized:** Panelized describes a method of construction, rather than a specific system. In traditional framing, the individual components of the house, such as studs, joists and rafters, are brought to the site and the house is built from individual pieces. In panelized construction, large panels are built off-site, then assembled on-site and secured to the foundation. These panels may make up the floors, walls, ceilings and roofs of the home.

There are varying degrees of panelization. Panels may be simple structural sections, or they may include siding, insulation, wiring and even interior finishes. Panelized construction may utilize wood framing, steel framing, or a combination of the two. The panels often include upgraded insulation treatment and less thermal bridging than found in conventional construction.

Once the home is constructed, there is generally very little difference between a site-built home and a panelized home, although manufacturers maintain that the better working environment and quality control possible in a factory, results in better built homes.

**DESCRIPTION** **6.1.6.4 Structural Insulated Panels (SIP):** Structural Insulated Panels (SIPs) are one type of panelized construction. SIPs include the structural member, insulation, air barrier and exterior sheathing. These types of panels are sometimes called stress-skin panels because the wood outer layers act like the flanges of a steel I-beam. The insulation acts as the web. We end up with a strong structural member without using a lot of material.

Structural Insulated Panels are typically 3 1/2 to 5 1/2 inches of expanded polystyrene insulation sandwiched between 4-foot by 8-foot plywood or oriented strandboard (OSB) panels. The insulation is typically 1 1/2 inches smaller than the skin at the top and bottom, so the panels can receive sill plates and top plates. Some panels have recesses in the insulation at the sides to accept plywood or OSB pieces to join adjacent panels.

**ELECTRICAL WIRING** Many panels include hollow chases in the insulation to accommodate electrical wiring. Foam has to be removed to make room for electrical boxes.

**OTHER MATERIALS** Similar products are also made, replacing the wood with steel, aluminum, concrete and fiberglass. Insulation materials are most often expanded polystyrene, but can be polyurethane or other materials.



### Common Problems with Panelized Walls

Rot, insect attack, mechanical damage, fire damage can all be problems with wooden components.

**WOOD DESTROYING INSECTS** While polystyrene is not a food source for pests, some wood-destroying insects will nest in, or travel through, the foam. Some SIP products contain chemical protection, and some SIP installations use mechanical barriers to protect against infestation.

**DESCRIPTION** **6.1.6.5 Rammed Earth:** As the name would suggest earth, or soil, is the primary component of a rammed earth wall. Native soil can sometimes be used, but a screened engineered soil is most often used. Ideal soils are about three parts sand to one part clay.

Forms are constructed on conventional foundations. The forms have plumbing pipes and electrical conduit placed prior to pouring the soil. A thick mixture of earth, cement and water is poured into the forms in layers (typically 8 inches thick). There is typically less than 5% cement and 5 to 10% water mixed into the soil. Each layer is compacted (to about five inches), and another layer is then added and compacted. Pneumatic tampers are typically used to compact the soil in the forms. The process is repeated until the wall is complete. An alternative approach uses a pump to shoot the mixture into one-sided forms with air pressure.

When the forms are removed, a rough surface is presented. This can be an architectural feature, or the walls can be covered with plaster on the interior and stucco on the exterior. Finished walls are typically 12 to 18 inches thick.

### Common Problems with Rammed Earth Walls

**POOR INSULATION** Rammed earth homes are less practical in northern climates where the thermal mass of the walls does not provide good insulating performance. The insulating value of an 18-inch thick wall may be R-4 or R-5, well below modern standards in cold climates.

**MOISTURE** Like many building systems, moisture is the enemy. While rammed earth walls are not damaged by occasional moisture, durability may be an issue in wet climates. Some types of soil are also more moisture-resistant than others. Exterior sealants are used in some cases to protect the earth walls from moisture. Large roof overhangs and raised foundations help keep the walls dry.

**DAMAGE** Mechanical or moisture damage may result in missing or loose sections of the wall covering or the wall itself. Areas close to grade may be more vulnerable.

**WINDOW SILLS** Windows may be installed close to the interior or exterior wall face. From a performance standpoint, windows close to the exterior surface are preferred, since this eliminates a wide exterior window sill that will trap water.

**DESCRIPTION** **6.1.6.6 Straw Bale:** Straw bale walls can be load bearing structural members, carrying the second floor and roof loads, or the bales may fill in between or wrap around a wood post and beam frame. In either case, the bales provide the insulation as well as the base for interior and exterior finishes.

Straw is the stalk of grains such as wheat, barley, rye, oats and rice. Straw should not be confused with hay, which is grass that is food for horses! Horses would not appreciate being fed straw. Straw is generally considered a waste by-product of agriculture and a nuisance because it is slow to decompose.

Straw bales used for building weigh 50 to 90 pounds each. Small bales may be 14 inches by 18 inches by 36 inches. The largest bales may be 18 inches by 24 inches by 48 inches. The walls are typically 13 to 24 inches thick plus the thickness of the finishes on the inside and outside.

Bale walls sit on conventional foundations that, with some exceptions, should be as wide as the bales. There is usually a moisture barrier between the top of the foundation and the first row of bales. Vertical steel reinforcing bar (re-bar) projects 12 inches out the top of the foundation to secure the bales to the foundation. The re-bar is typically 1/2 inch diameter and is placed in the center of the foundation, every two feet along the wall length, and within 12 inches of all corners.

The bales are stacked like large bricks into a wall configuration, and are sometimes connected to each other with steel rebar, or wood or bamboo stakes. Water pipes in the bales are installed in continuous sleeves to protect the bales from damage due to leakage.

Stucco over wire mesh is the typical finish outside, and it can be used as the inside finish as well. Lime or clay based plasters may be applied directly to the interior of the straw bales without reinforcement. The inner plaster and outer stucco finishes add strength and rigidity, making the wall a stress skin panel.

**STUCCO** Exterior stucco should breathe. Stuccos with lime tend to be more permeable and allow walls to dry to the outside. Other stuccos are less permeable and do not allow moisture vapor to pass through. This restricts the drying potential of the wall, and may lead to mold or rot in the bales. Elastomeric stuccos like Exterior Insulation and Finishing Systems (EIFS) for example, are also impermeable and do not promote drying.

### Common Problems with Straw Bale Walls

- FIRE** Fire vulnerability is roughly the same as for wood frame walls. Fire is actually less of a problem with straw bale than wood frame because it is harder to ignite. Straw bale walls do not have the natural chimneys that occur in wood frame walls. However, once the fire is established, straw bales contribute more fuel than wood frame construction. The slower-to-ignite issue may be more important for occupant safety.
- ROT** Straw bale walls are vulnerable to moisture problems, like most other exterior walls. Straw bale homes with flat roofs may be more prone to failure due to water damage from the roof. Flat roofs often accumulate water, and a leaking roof may provide a chronic water source into the walls.
- BELOW GRADE** Straw bale walls should be built well above grade level to prevent moisture damage. Raised foundations help keep the bales dry. Large roof overhangs also help keep the walls dry.
- CRACKS** Cracks in the stucco and any openings around wall penetrations are vulnerable points. The goal is to keep the moisture out of the home. Moisture content is usually limited to 20%. Some straw bale houses have moisture meters built in to monitor moisture levels in the bales.
- DESCRIPTION** **6.1.7 Party Walls:** Party walls or common walls separate two homes in the same building. Their main function is to prevent the spread of fire from one home to the next.
- MASONRY** Masonry party walls provide relatively good fire protection between the two houses, although they don't block sound very well.
- WOOD-FRAME** Wood-frame partition walls provide less fire protection, although they can be better from an acoustic standpoint. Some party walls are masonry part of the way up through the house, and wood-frame in the attic.

### Common Problems with Party Walls

- NONE IN ATTIC** In some attached houses, there is no wall between the attic areas. This space can allow fire to spread quickly from one home to another. Modern construction rules do not permit this arrangement.

### 6.2 Arches and Headers (Headers are also called Lintels)

- DESCRIPTION** Arches and headers transfer the load above an opening in a masonry wall to the wall sections on either side.
- LOADS IN MASONRY WALLS** The arch or header supports a triangular section of masonry above the arch. The height of the triangle is roughly half the width of the opening. This means that a window with twenty stories of brick above requires only the same arch as a window with six feet of brick above.

There are several types of arches. Stone, brick and concrete are the most common materials used. Segmental arches are the most common, made up of several pieces. The arch typically has a rise of at least one inch for each foot of its span.

Jack arches have flat tops and bottoms and are often decorative but not functional. Steel headers typically support the arch. This is not a common type of arch.

Some arches have a larger masonry unit at the top/center. This is called a keystone, and is often the architectural focus of an arch and window system.

Headers are typically flat, and use the inherent strength of the material to transmit the load, rather than the arch principle. Headers (called lintels in some areas) may be steel, wood, stone or concrete.

Headers are made of a single piece, where arches are built from several pieces.

### Common Problems with Arches and Headers

**TOO FLAT OR TOO NARROW** Failure in arches is common where the rise is very modest, or the arch is not quite wide enough to clearly span the opening. Another common problem with arches is slight movement of the walls on either side. This is particularly common where a window or door opening is close to the end of a wall. On one side of the arch, there may not be enough mass to resist the lateral thrust of the arch transferring its load to the wall beside. As the thin section of wall pushes outward, the arch drops.

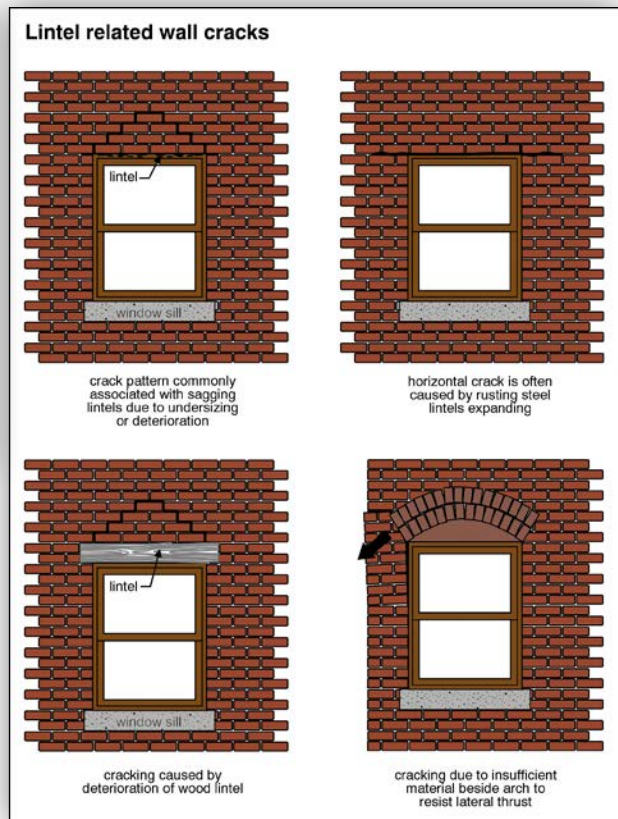
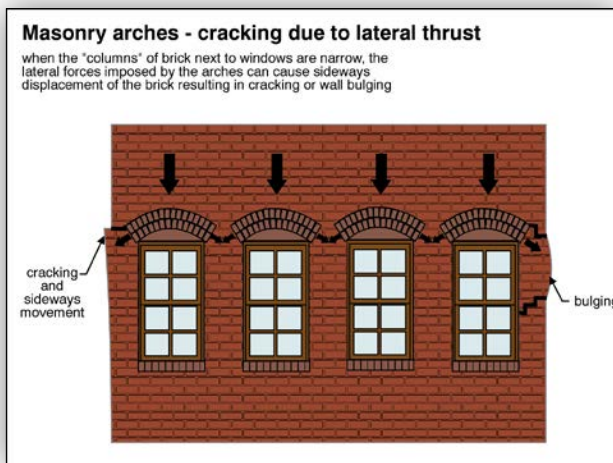

- DETERIORATION/LEANING** Mortar or masonry deterioration can, of course, lead to failure. Building settlement may allow the arch to open up and drop. Another problem is forward movement of the arch out away from the building. This is usually caused by foundation movement or mortar and masonry deterioration. Corrective actions include rebuilding the arch or adding a header.
- UNDERSIZED/POOR END BEARING** Headers may be undersized for the load. Inadequate end bearing of the headers may lead to failure. Steel headers (lintels) on masonry walls should extend at least six inches beyond the opening on either side. This cannot usually be seen.
- RUST/ROT/SPALLING / CRACKING** Steel lintels are subject to rust. The rusting steel expands and may cause horizontal cracks in the mortar joints at the corners of the opening. Wood headers are susceptible to rot and insect attack. Concrete and stone headers are subject to cracking or spalling.
- MISSING** In amateurish construction projects, windows may be added to masonry walls or brick veneer walls with no arch or header provided. This will often work in the short term, but problems usually develop over time. Missing or inadequate headers should be replaced.
- CAULKING** Steel headers (lintels) supporting brick veneer should have no caulking between the steel and the brick above. Caulking may trap water and rust the steel.

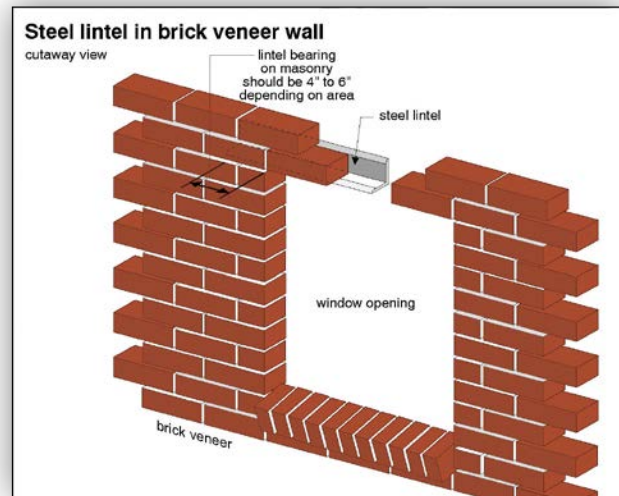

## 7.0 Roof Framing

**DESCRIPTION** The roof framing is an assembly of wood or steel components. The roof framing ties the building together, adding rigidity and providing a surface for the roof covering. The roof framing also supports the ceiling finishes below. We will look at the individual components of roof framing systems.

### 7.1 Rafters – Wood

**DESCRIPTION** Rafters carry the loads from the roof sheathing, roof covering, wind, water, snow and ice. These loads are transmitted through the rafters to bearing walls or beams below. The term rafter is associated with sloped roofs. When these members are found on a flat roof, they are horizontal and called roof joists, although they do the same job.

Rafters can usually be seen overhead when standing in the attic. Some rafters support finished ceilings, creating a cathedral ceiling. In this case, insulation is often fit between the rafters.

Wood rafters are typically 2x4s, 2x6s or 2x8s, spaced 16 to 24 inches on center. Conventional rafters have been replaced by trusses in most modern home construction. The engineered trusses can span greater distances less expensively than conventional rafters.

When calculating the span of a rafter system, the horizontal span rather than the actual length of the rafter is used. Knee walls or purlins may provide intermediate support, reducing the span. Collar ties help keep rafters in place. Ceiling joists are horizontal members that often tie the bottoms of opposing rafters together, making a strong triangle.

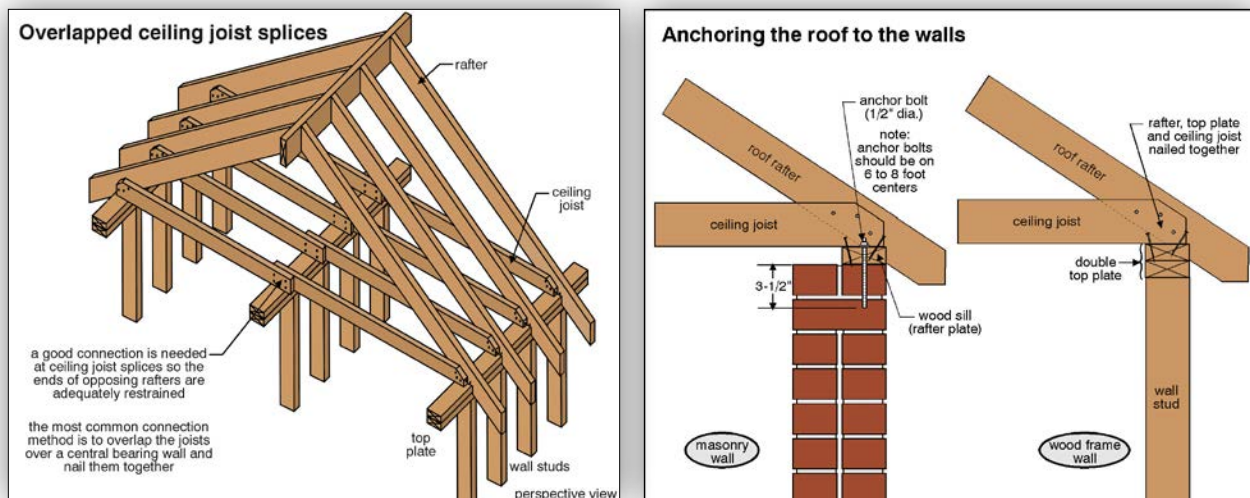



## Common Problems with Wood Rafters

**OVERSPANNED/  
RAFTER SPREAD** If rafters are overspanned or spaced too far apart, the roof will sag. If rafters are not adequately secured to the walls at the bottom edge, the rafters may spread apart. This is common on older houses, particularly with gable roofs. It is often noted at the eaves, because the soffits pull away from the house wall as the rafters spread. In other cases, the spreading rafters push the top of the wall outward. This can be very serious.

Rafters may also separate at the roof ridge if connections and support are poor.

**ROT/INSECT  
DAMAGE/SPLIT** Wood rafters are susceptible to rot, insect, fire and mechanical damage. Rafters may split under load.

**CONDENSATION  
LEADS TO ROT** Attics in cold climates with good insulation but poor ventilation may be susceptible to condensation problems. Condensation will attack the roof sheathing and the rafters. Left unchecked, this can lead to roof structure failure. Corrective action includes improved ventilation and replacing damaged wood. Mold often develops in attics as a result of condensation.

**SAG–  
CONCENTRATED  
LOADS** Concentrated loads may be a problem around roof dormers. The load from a dormer is transferred to the rafters on either side of the dormer. Unless these rafters are strengthened, the roof may sag around dormers.

In cold climates, roofs may fail because of a concentrated snow load. Split-level houses are susceptible to this problem, for example. It is not unusual for snow drifts to form on the lower roof, near the wall of the higher section. This leads to big loads on the rafters or trusses in these areas. The rafters may crack, sag or spread at the bottom. Trusses may collapse.



## 7.2 Roof Trusses – Wood

**DESCRIPTION** Roof trusses are engineered assemblies that perform the same function as rafters, collar ties, knee walls, purlins and ceiling joists. The roof truss carries the roof sheathing and shingles, and the live loads, transferring the roof loads to the outside or bearing walls. The bottom of the truss also supports the ceiling finish.

There are other engineered wood framing systems including wood I-joists, and other configurations. A design review of these is beyond the scope of a home inspection. The performance evaluation is similar to trusses and rafters.

Most trusses in homes are made of wood. The top and bottom members of the truss are called chords. The interior members of a truss are called webs. Truss members are fastened together with gusset plates. These may be made of plywood or steel. Different configurations of trusses have different strengths, and engineers can use the shape and component size that best suits them. Trusses are engineered systems. Trusses are normally spaced 24 inches apart, but this can vary, again depending on the spans and depth of truss desired.

There are two common truss types used residentially. The Fink or “W” has web members that form a “W”. The Howe truss can be identified by vertical web members, including a vertical web running up to the peak. There are many variations of these found in residential construction.

In either truss type, the webs should be at least 2x4s, unless special engineering consideration has been given. Where the compression webs are longer than six feet, they are susceptible to buckling under heavy loads. Braces, such as 1x4s, should be fastened to the midpoints of these webs.

Where the bottom chord has a long span between support points, it may not be strong enough to carry the ceiling load. If the span is more than ten feet between support points, the bottom chord should be at least a 2x5. If the span is more than 12 feet, the bottom chord should be a 2x6. Again, special engineering consideration can result in deviations from these guidelines.

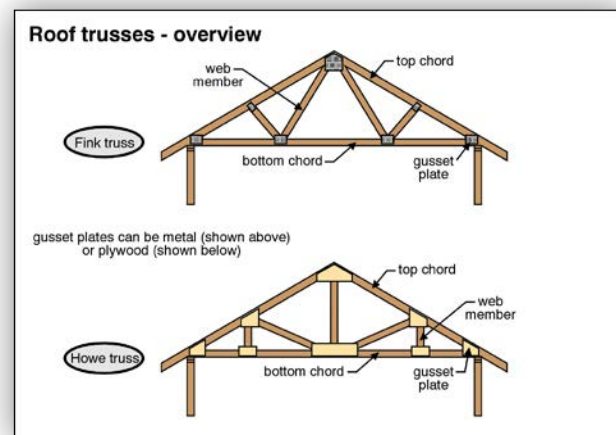

### Common Problems with Wood Roof Trusses

Like any wood member, trusses are subject to rot, insect damage, mechanical damage and fire.

**CUT** Individual chords or webs that are cut or damaged can be a serious problem. Cutting a truss in one spot may seriously compromise the entire truss. Where trusses are cut to accommodate chimneys or other interruptions in the roof line, engineering consideration should be given.

**FASTENING** Trusses must be well secured to perform well.

**OVERSPANNING** Overspanning of trusses can lead to deflection and, in worst cases, roof collapse. Heavier roof material such as concrete tile, or greater snow loads than expected, due to unusual conditions or drifting may cause the problems. Overspanning cannot be identified during a home inspection, but evidence of deflection or failure is noted.

**REPAIRS – DESIGN NEEDED** Reinforcing overspanned or damaged trusses is more difficult than strengthening a rafter roof system. An engineer should design the repair.

**LONG WEBS – BRACING NEEDED** Trusses with web members longer than six feet may be subject to buckling. Braces should be added to the midpoints of the webs. One brace attached to each web with two nails should connect several webs in adjacent trusses. The braces should be at least 1x4s.

**INADEQUATE CEILING SUPPORT** Undersized bottom chords should be stiffened to prevent ceiling sag and cracking of ceiling finishes. Adding a second member to the bottom chord would normally be satisfactory.

**TRUSS UPLIFT** A phenomenon known as truss uplift is relatively common in cold climates. The temperature and humidity changes in the attic during the winter months affect the sections of the truss above the insulation level differently than the bottom chord, which is buried in the insulation. This results in an upward bowing of the bottom chord.

The result of truss uplift is that the center section of the bottom chord moves up, and gaps as large as 1-1/2 inches appear at the top of the interior walls, where they join the ceiling. The ceiling is picked up by the truss. It is also possible that the interior wall below will be lifted up, and separation will occur between the wall and the floor.

A common solution is to secure a molding to the ceiling (but not to the wall). As the ceiling moves up and down, the molding will slide up and down the wall, concealing the gap.

Another solution is to disconnect the ceiling finishes from the truss during construction and to clip the ceiling finishes to the wall. This allows the ceiling to bend very slightly, but not to crack.

Truss uplift is not a serious structural problem.

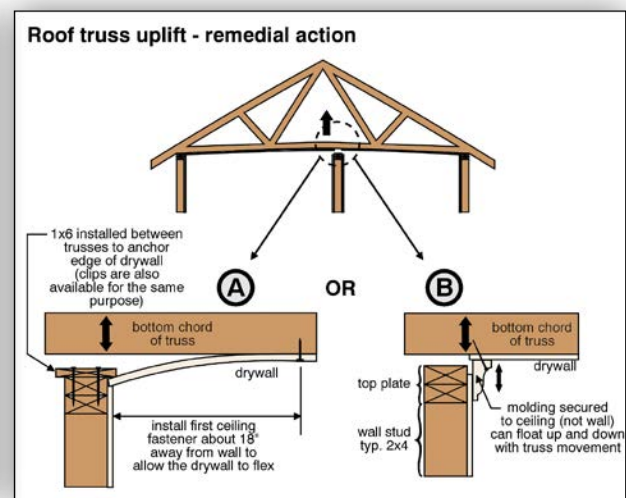
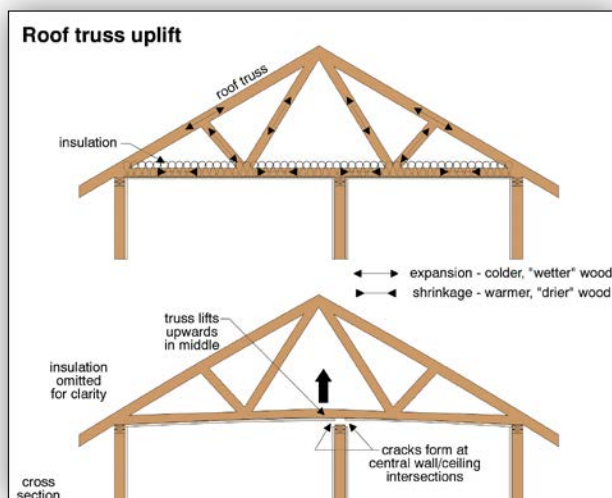

### 7.3 Steel Framing

**DESCRIPTION** Steel roof framing performs very much like wood framing. Like wood, steel roof framing may be manufactured trusses or site-assembled rafters and joists. The principles of wood framing also apply to steel roof framing, although continuous bridging on the rafters is often needed, either on the underside, or through the knockouts. The undersides of joists will twist and move unless they are restrained.

Wood sheathing materials, such as plywood, are screwed to the steel roof structure. Roofing materials are installed over this sheathing as normal.

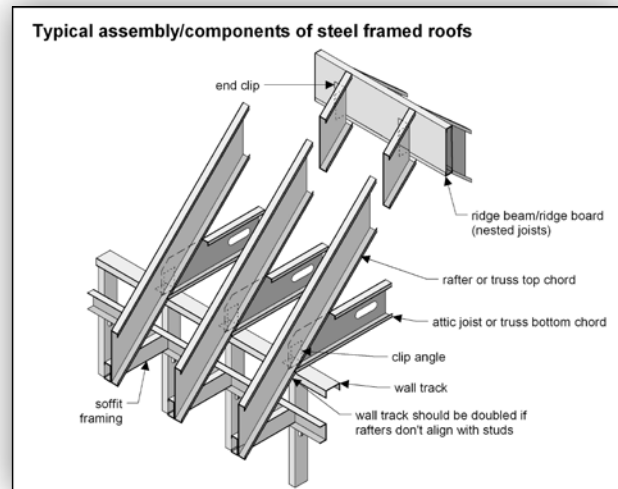

#### Common Problems with Steel Roof Framing

**RUST** Steel is, of course, vulnerable to corrosion with long-term exposure to moisture.

**HOLES** Any holes that are created should be at least 10 inches away from the end of the rafter, positioned in the middle of the rafter, and should not be wider than 1-1/2 inches and not longer than four inches, unless they are reinforced.

**NO DESIGN REVIEW** Steel roofs are engineered systems, and as with wood trusses, home inspectors do not assess their design.

## 7.4 Collar Ties

**DESCRIPTION** Collar ties may be installed to prevent rafter movement. These are typically wood members (at least 1x4s) installed horizontally across the attic space. They are connected at either end to opposing rafters. In some circumstances, metal straps may be used instead of collar ties to prevent uplift.

### Common Problems with Collar Ties

- MISSING, WRONG LOCATION OR POOR CONNECTION** Missing collar ties can be added readily. Collar ties may be installed incorrectly or fastened poorly.
- BUCKLED AND BROKEN** When collar ties are installed to prevent rafter sagging, the compression from opposing rafters may buckle and crack the collar ties. Adding braces will prevent this. Broken collar ties can be replaced as needed.

## 7.5 Purlins

**DESCRIPTION** Purlins prevent rafter sag. These are wood components the same size as the rafters they support. They are nailed to the underside of the rafters and are supported, in turn, by 2x4 braces, which extend down, usually on an angle rather than vertically, to a bearing wall below. See illustration on next page.

### Common Problems with Purlins

Like any wood component, purlins are subject to rot, insect and mechanical damage.

- STRUTS – MISSING** Braces or struts no more than four feet apart should support the purlins.
- STRUTS – SLOPE** Struts should be installed with a slope of not less than 45 degrees from horizontal. Any less than this and the struts will not properly transfer their load.
- STRUTS – UNBRACED** The struts themselves should be braced if they are longer than eight feet. A strip of lumber attached perpendicular to the struts will prevent buckling.

## 7.6 Knee Walls

**DESCRIPTION** Knee walls are intermediate supports that prevent rafter sag. These small walls in the attic are typically built with 2x4 wood studs. They run from the attic floor up to the underside of the rafters near their mid-point. In 1-1/2 or 2-1/2 story houses, knee walls form the walls of a room on the upper floor. These rooms often have a partly sloped ceiling as a result.

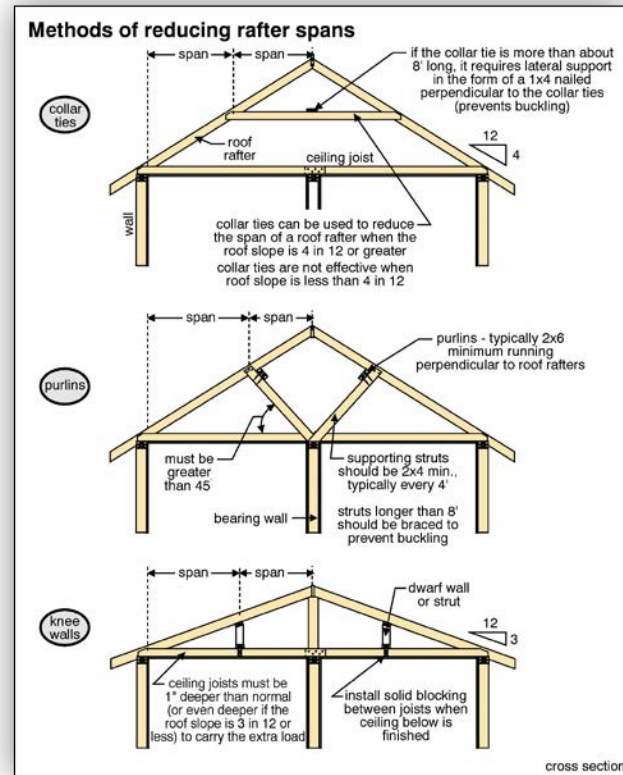

### Common Problems with Knee Walls

- POORLY SECURED/ WEAK FLOOR** If the knee walls are not adequately secured to the rafters above or the joists below, they will move. If the floor joist system below is not strong enough, or there is no partition below, this can lead to deflection and damage in the ceiling below.
- LOCATION** If the knee wall is not near the mid span of the rafters, it may not be effective in preventing rafter sag.
- DAMAGE/ROT/ INSECT DAMAGE** Like any wood component, knee walls are subject to rot, insect and mechanical damage.



## 7.7 Roof Sheathing

**DESCRIPTION** Sheathing supports the roof covering, transmitting the loads from the covering and the live loads due to water, snow and wind to the rafters, trusses or roof joists.

Up until the 1950s, virtually all roof sheathing was wood plank. Plywood roof sheathing in 4-foot by 8-foot panels became popular in the 1960s, and waferboard panels arrived in the 1970s.

Plywood should be laid with the surface grain perpendicular to the rafters, trusses or joists. The eight-foot length should be across the rafters with each end supported by a rafter. The other edges should also be supported, typically by metal “H” clips located between rafters. These clips not only support the edges, but keep the sheets slightly separated to allow for expansion without buckling.

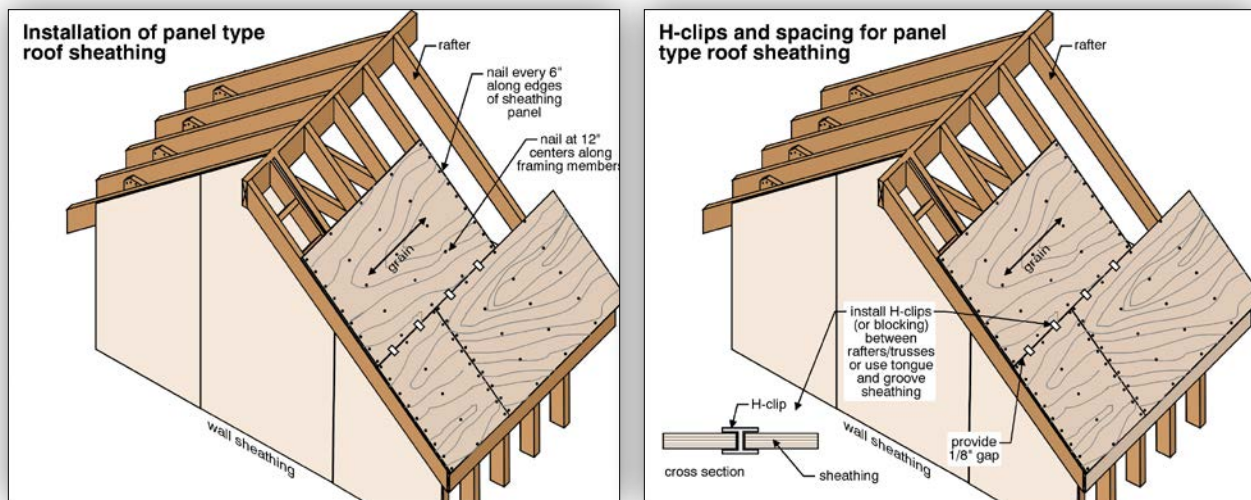

The thickness of the sheathing is determined by the spacing of the rafters and the live roof loads. Modern construction typically employs trusses or rafters on 24 inch centers and plywood sheathing 3/8 inch thick (or waferboard sheathing 7/16 inch thick). This leads to a fairly springy roof surface when walked upon. Unusually heavy loads or slight weakening of the plywood due to high moisture levels in the attic can lead to sagging of the sheathing between the supports. Normally this is not a structural flaw, although it is unsightly.

## Common Problems with Roof Sheathing

**DAMAGE/ROT/  
INSECT DAMAGE** Like any wood component, roof sheathing is subject to rot, insect damage and mechanical damage.

**DAMAGE –  
CONDENSATION** Condensation in an attic can cause problems. Plywood roof sheathing will begin to delaminate and waferboard sheathing will swell. This can cause loss of sheathing strength and render the nailing ineffective as nails are pulled out of the rafters or through the sheathing. In severe cases, the roof covering has to be removed and the sheathing replaced.

Concealed condensation in cathedral roofs is a common problem and considerable damage can occur before there are any visual clues.

**MOLD** Mold often appears when there has been condensation in the attic. Once the moisture is removed, the mold stops growing. Removal of the inactive mold is not necessary, although many homeowners remove it because of the stigma attached to mold.

**TOO THIN** Sheathing that is too thin for the application will sag under load. Aesthetically, this is often unacceptable, although sagging to the point of failure is unusual.

Sheathing thickness is determined in part by the spacing of the rafters or trusses below. Thicker sheathing is needed when the spans are greater. Sheathing thickness is also determined by the live loads from wind and snow as well as dead loads from roof coverings.

**EDGE SUPPORT** Unsupported edges of roof sheathing may lead to differential movement between two panels. This can lead to horizontal ridges appearing in the roofing. If the sheathing is unusually thick, edge support is not necessary.

**FIRE RETARDANT  
TREATED (FRT)  
PLYWOOD** Fire retardant treated (FRT) plywood was recognized as a problem in the late 1980s. Delamination and weakening of this plywood can lead to a loss of roof shingles and ultimately collapse. Where it has begun to fail, it should be replaced.

## 8.0 Masonry Chimneys

**DESCRIPTION** The structural function of a chimney is to carry its own weight down to the foundations and footings without moving. (We look at other chimney functions in the Roofing and Heating chapters.)

### Common Problems with Masonry Chimneys

**LEANING** Chimneys that lean above the roof level should be braced or repaired as necessary, without delay.

**FOUNDATION PROBLEMS** Localized foundation settlement in a house around the chimney is fairly common, typically because the foundations were not large enough to carry the weight of the masonry. The chimney may eventually fall over, but the problem can become very serious before this point. A chimney that begins to lean or pull away may develop cracks or gaps, which allow smoke and heat to get near combustible materials, creating a fire hazard.

**CRACKING/ DETERIORATED MASONRY OR MORTAR** Cracking, spalling and deteriorated mortar are common problems with any exterior masonry.

**CORBELLING** Chimneys with excessive corbelling (one row of bricks projecting out and overhanging the row below) or undersized foundations are prone to movement. (See Section 6.1.1)

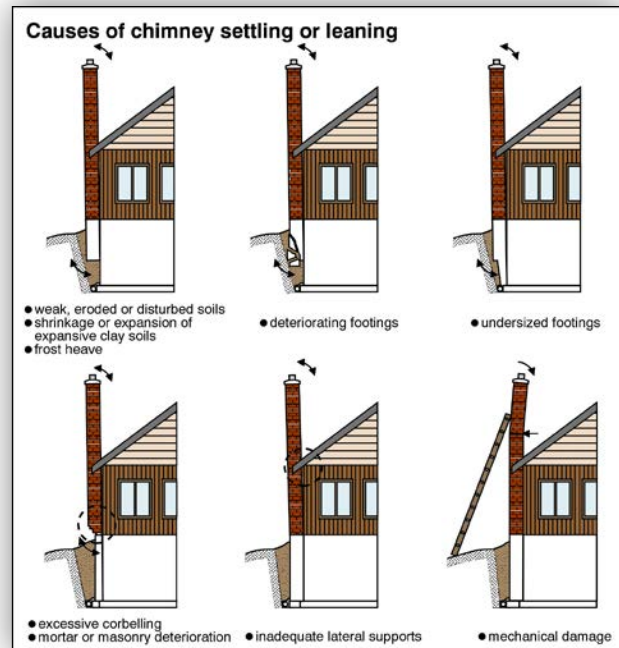

**THREE SIDED** Occasionally, chimneys are added to the outside of existing houses. Many of these are only three sided, using the house wall as the fourth side. This is usually considered unsafe although it may be acceptable where a brick veneer wall is made of solid masonry units and is spaced out at least 1/2 inch from combustible sheathing. On masonry walls, 12 inches of solid masonry must separate the flue from any wood joists or beams. A visual inspection cannot determine whether the installation is safe.

**WOOD** Wood building members should not contact masonry chimneys to avoid overheating.

**CONTACTING CHIMNEYS** Generally speaking, interior wood should be at least two inches from the chimney. On exterior wood, this can be reduced to 1/2 inch. Where it is necessary to frame into the chimney, there should be 12 inches of solid masonry between the wood and the flue.

**FIREBLOCKING MISSING** The space between masonry chimneys and wood framing can provide a channel for fire to move quickly up through house. Fireblocking at ceiling levels helps prevent this. The blocking material can be compressed fiberglass insulation or other non-combustible material. It is often difficult to see during a home inspection whether this has been installed.

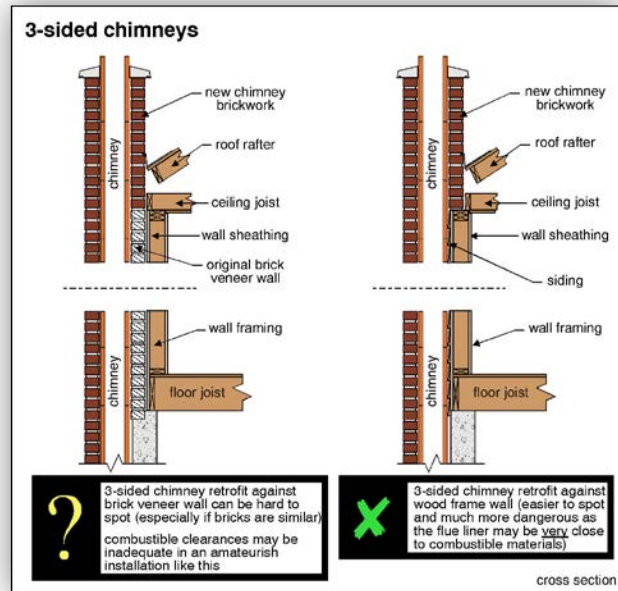

## 9.0 Things That Cause Structural Problems

**DESCRIPTION** Let's look at some of the common things that go wrong with the structure. While there are some problems that are specific to one component (truss uplift problems, for example, are unique to wood roof trusses), there are two broad sources of problems – poor construction and things that attack the building.

### 9.1 Poor Construction

**DESCRIPTION** House components may fail because they were built with improper materials, or the materials were poorly assembled. Examples include undersized structural members like footings, beams and joists. Poor connection issues include inadequate nailing, missing or poorly installed joist hangers, bad post-to-beam joints, or using the wrong fasteners, like nails instead of bolts to secure a deck to a building.

There are hundreds of examples of poor construction practices common to homes.

## 9.2 Things that Attack Houses

**DESCRIPTION** Let's assume the home was properly built. We are not out of the woods yet! Lots can still go wrong, and often does. Some of the things that happen are universal, and some are specific. Rot and insects attack wood members but not concrete, for instance. We'll start with some things that apply to all or most homes, and then move to some that are regional.

**DESCRIPTION** **9.2.1 Rot Affects Wood:** All wood and wood-based building materials are subject to rot. Components that are more likely to get wet frequently are more likely to rot.

**FUNGUS** Rot occurs in wood under certain conditions of temperature, moisture and in the presence of oxygen (It's always present!). The decay is caused by fungus, which attacks the wood cells, causing the cells (and the wood as a whole) to collapse. The fungus that causes rot requires a temperature between 40° F. and 115° F. to be active. Above that temperature, the fungus can be killed and, below that temperature, the fungus becomes dormant, but can be reactivated once the temperature increases.

**MOISTURE NEEDED** Sufficient moisture is needed for rot to occur. When the moisture content of the wood exceeds approximately 20%, fungus spores that are naturally present in the atmosphere can be sustained and grow within the wood. Once the fungus is established, it will continue to grow and decay the wood as long as the wood remains wet. If the lumber is dried to below 20% moisture content, the rot will spread no further and will become dormant.

As the rot progresses, the wood cell walls collapse, leading to a loss of strength and the formation of cracks perpendicular to and parallel to the grain. The wood can often be broken off in small cubes.

**OXYGEN NEEDED** Oxygen must be present for rot to develop. This explains why wood submerged in water will not rot. Under normal circumstances in houses, there is always oxygen to support rot fungi growth.

### Recommended Practices and Solutions for Rot

**AVOID TRAPPED WATER** Wood structures must be properly designed to resist rot. Wherever possible, the design should prevent cyclical wetting and entrapment of moisture. All joints should be free draining to dry quickly. Ledges, valleys and troughs where water can collect should be avoided. End grains of wood should be well protected, as they are capable of soaking up large amounts of water through capillary action.

**ROT RESISTANT WOOD** Some woods, including cedar and cypress, for example, are naturally resistant to decay fungi. Various wood treatments (such as pressure treating), can enhance the rot resistance of wood. In the case of pressure treating, copper arsenate salts (typically) are forced into the wood cells under pressure. It is these salts that give the wood a greenish tint. There are other treatments designed to provide resistance to rot, mold and insect attack. They can produce wood of different colors, including blue.

**AVOID WOOD/ SOIL CONTACT** Avoiding the direct contact of wood with soil will inhibit rot by helping to keep it dry. Good ventilation of porches and crawlspaces, for example, is also important in eliminating rot.

**PREVENT LEAKS** Appropriate flashing details at joints that promote good drainage, and a well-maintained protective coat of paint or stain, will also help to fight rot. Leaking roofs and gutters, if uncorrected, can create an ideal environment for the establishment of rot fungi. Similarly, wood in the area of kitchens and bathrooms can be susceptible to rot if there are leaking pipes or fixtures.

**DESCRIPTION** **9.2.2 Insects Attack Wood:** Insects can do serious damage to wood structures. Termites do the most damage because they eat the wood, but there are many insects that damage wood by nesting in it. These include carpenter ants and powder post beetles.

Home inspectors do not perform pest inspections as part of a home inspection. But they do look for evidence of the structural damage that results. The evidence is often hidden or very subtle.

**DESCRIPTION** **9.2.3 Fire Attacks Wood and Steel:** Fire damage to a building can be severe or cosmetic. As a very general rule, major structural members with less than 1/4 inch of char do not require re-supporting. This, of course, depends on the size, orientation and function of the member. Where there is doubt, specialists can be consulted.

Another type of fire damage should be considered. Where wood structural components are too close to fireplaces, furnaces, etc., the wood around them may begin to char as it overheats. This can occur at temperatures as low as 250° F. This will allow the wood to ignite easily if exposed to higher temperatures even briefly. Charred wood around heat generating appliances is a danger sign that should not be ignored.

Although steel does not burn in the sense that wood does, it loses its strength quickly when exposed to fire. Steel members typically fail before wood components in a fire.

**DESCRIPTION** **9.2.4 Rust Attacks Metal:** Rust or corrosion affects most metals to some extent. Rusting steel is a common house problem with respect to posts and beams as well as fasteners like nails, screws and bolts. Unprotected steel rusts when exposed to water. Steel that is expected to be wet can be painted or treated with rust inhibitors such as galvanizing (adding zinc to the steel to resist rust). Hot dip galvanizing is more effective than electroplate galvanizing, although neither guarantee that there will be no rust. Stainless steel is more corrosion resistant than galvanized steel but is not common as a building material. There are different types of stainless steel.

**EXPANDING RUST** Rust can cause metal components to weaken but can also damage other materials. Steel expands as it rusts, exerting tremendous force. If the steel is embedded in concrete, the damage can be significant. Steel reinforcing bars can break (spall) concrete and steel railings can damage concrete porches, decks and balconies, for example.

**DESCRIPTION** **9.2.5 Mechanical Damage Affects All Building Materials:** Wood and steel are more susceptible than concrete, but damage is possible in any of these.

Mechanical damage to wood members can take several forms. It may be split, broken or crushed during handling or while the building is under construction. It is common for some wood in a home being built to suffer minor mechanical damage. The extent and location of the damage determine whether replacement or repair is needed. The entire system must also be considered. If the wall, roof, or floor system is significantly over-designed, one damaged member may not be critical.



- NOTCHES AND HOLES** Similar consideration is given to mechanical damage caused by cutting, notching or drilling holes in wood members. Again, there are several criteria that help determine whether corrective action is warranted.
- IMPACT DAMAGE** Impact damage may be from vehicles, animals or people. The damage can be trivial or devastating.
- DESCRIPTION** **9.2.6 Ground Movement – Earthquake and Soil Conditions:** No matter how well the home is built, when the ground below moves, damage is likely. Earthquakes are significant problems in some parts of North America. Erosion, landslides and underground streams undermining buildings are examples of less dramatic ground movement. Homes built on weak soils may fail catastrophically. Expansive soils can also cause dramatic building damage. Another kind of soil movement specific to cold climates is frost heave, where the soil below or beside the building damages concrete floors and walls.
- Construction techniques can improve the chances of successfully withstanding damage, but there are no guarantees with nature. During an earthquake, the house should act as a unit, with the foundations, floors, walls, and roof moving together. Problems arise when these move independently of each other.
- RISK FACTOR** Unreinforced masonry buildings and structures are more vulnerable to earthquake damage than wood frame homes. Wood frame homes with shearwalls are better than ordinary wood frame buildings. Homes with the structural components tied together and tied to the foundation are better than conventionally framed houses. Single story homes are better than two story homes.
- COMMON PROBLEMS** Failure modes during earthquakes typically include things like posts moving off piers, beams moving off posts, cripple walls falling off foundations, and masonry chimneys collapsing.
- TWO STRATEGIES** The two critical strategies in reducing earthquake damage are tying the house structural components together and using shearwalls to minimize racking of the structure.
- TYING HOMES TOGETHER** Special fasteners are used, both during new construction and in upgrading existing homes. The hardware includes sill anchors (mechanical wedge-type in retrofit situations), hangers, hold downs (tie downs), post caps, straps and hurricane clips (hurricane ties). Wood members can also be used to tie components together.
- SECUREMENT** The fasteners may be nailed, bolted or embedded in concrete. Engineers, manufacturers and designers have differing opinions about the type, size, location and number of fasteners required in any situation. The goal is to tie the building together to prevent lateral movement or overturning. The sills should be tied to foundations or floor slabs, posts should be tied to piers, beams should be tied to posts, floors should be tied to sills, walls should be tied to floors and sills, and roofs should be tied to walls.
- BRACING POSTS** Adjacent posts in sub-grade areas may be supported with 2x4 diagonal braces to help resist lateral forces.

**SHEARWALLS** Shearwalls help wood frame walls resist racking caused by the strong lateral forces that occur during earthquakes. Shearwalls are typically 3/8 to 1/2 inch plywood or waferboard. They must extend the full height of the wall to be effective. Shearwalls are typically the exterior walls of a wood frame home. Some interior walls on large homes may also be shearwalls.

**DETAILS** The plywood or waferboard panels may be installed on the inner or outer faces of stud walls. They are not needed on both. The panels are installed vertically, except on cripple walls less than four feet tall. Gaps of roughly 1/8 inch are left around all edges of panels to allow for expansion due to changes in moisture content. Without these gaps, the panels may buckle when they swell.

**SECUREMENT** Panel edges are nailed every four to six inches, depending on the designer and the situation, and every 12 inches in the field of the panels. All four edges of panels must be backed by something solid such as sills, studs, rim joists, top plates or blocking.

**HOLD DOWNS** Hold downs are provided at each corner of the home and at each end of every shearwall. Hold downs are heavy L-shaped brackets that secure the shearwall to the foundation. Hold downs are usually secured with bolts.

**CRIPPLE WALLS** Cripple walls are short wood frame walls that span from the foundation to the first floor. They are vulnerable to earthquakes because they have little resistance to lateral forces. Cripple walls can be converted to shearwalls from the inside by adding plywood or waferboard panels to the studs. Stud spaces are typically vented into the sub-grade area with 1/2 inch diameter holes at the top and bottom of each stud cavity.

**STRAP APPLIANCES DOWN** Heavy appliances such as water heaters, furnaces, refrigerators, washing machines and stoves should be strapped to the building to keep them in place.

**SPECIAL GAS VALVES** Gas valves that shut off automatically if the gas line ruptures can be provided near the gas meter in earthquake prone areas.

**CHIMNEYS** Unreinforced masonry chimneys are common on old homes and there is no easy way to improve their resistance to earthquake. Some people put 3/4-inch plywood on attic floors to prevent bricks falling off chimneys from coming through ceilings into the home.

**DESCRIPTION** **9.2.7 Hurricane and Tornadoes:** Earthquakes impose lateral forces on homes, for the most part. Hurricanes exert lateral forces and uplift forces. While similar to earthquakes in some respects, hurricanes, tornadoes and other high winds present separate problems.

**RISK FACTOR** Hurricanes are regional issues, and there are other wind-related problems such as twisters and tornadoes that are also somewhat regional. The southeastern United States is the most prominent hurricane area in North America. Several devastating hurricanes have occurred in this area and building officials, insurance companies, builders and homeowners all look at homes differently as a result.

Considerable investigation and research has been done after hurricanes, and much has been learned about the mechanisms of failure. Hurricanes usually carry heavy rains and much of the damage from hurricanes is caused by water. Wind is not the only issue, but often creates the openings that allow water into homes. Wind carried projectiles are another problem.

- KEY ISSUES** Many believe the three key issues in hurricane resistance for homes are: the roof sheathing must be well secured to the roof framing, the roof framing must be well secured to the walls, and openings including doors and windows must be protected from flying debris.
- DECK NAILING** Roof sheathing should be nailed at six-inch centers along panel edges and at 12-inch centers in the field. Sheathing at overhangs is often nailed at four-inch centers because wind forces can be greater here.
- HURRICANE CLIPS** Hurricane clips or straps are used to secure roof framing to walls. Straps are also used to fasten wall top plates to the walls themselves.
- OPENINGS** Openings can be protected through special impact resistant doors and windows, or shutters, plywood covers or some other shielding protection on the outside.
- ROOF BRACING** Truss roofs can be strengthened with wood braces on the webs and the chords. Gable end walls have proven vulnerable to hurricane winds, and are often strengthened with braces in the attic.
- WIND RESISTANT SHINGLES** Asphalt shingles are often blown off roofs during hurricanes and other high winds. Manufacturers have been making efforts to increase the wind resistance of roofing materials. Some areas call for mopped-in asphalt underlayment beneath shingles where the risk of shingle loss is significant.
- CONCRETE TILES** Concrete tiles have also blown off roofs in hurricanes. These are worse than asphalt shingles because the heavy tiles become dangerous projectiles. Improved installation techniques include full mortar beds for concrete tiles.
- HIP ROOFS** Designers are being encouraged to move from gable roofs to hip roofs, since hips are less likely to fail. Hip roofs have no vertical gable wall to 'catch the wind'.
- GARAGE DOORS** Garage doors have been a problem because they blow in easily. Stronger doors, hardware and tracks are a partial solution.
- NO GUARANTEES** As with earthquakes, homes can be built to improve their chance of surviving serious winds, but nature is so strong that there are no guarantees.
- DESCRIPTION** **9.2.8 Flood:** Flood damage can be severe and may be the most serious impact of hurricanes and earthquakes.
- Homes in flood prone areas may be built on stilts to reduce the risk of damage or loss of building, but there are few absolutes with flooding, as with other natural forces.